



CEMBRE

DYNAMIC LOAD BALANCING BOX
 DISPOSITIVO DI BILANCIAMENTO DINAMICO DEL CARICO
 DISPOSITIF POUR L'ÉQUILIBRAGE DYNAMIQUE DE LA CHARGE ÉLECTRIQUE
 DISPOSITIVO DE EQUILIBRIO DINÁMICO DE LA CARGA
 DISPOSITIVO DE EQUILÍBRIO DINÂMICO DA CARGA

DLB1 DLB3 DLB1-PV DLB3-PV

**CE
UK
CA**



ENGLISH	INSTALLATION AND USER MANUAL	3
ITALIANO	MANUALE DI INSTALLAZIONE E USO	21
FRANÇAIS	MANUEL D'INSTALLATION ET D'UTILISATION	39
ESPAÑOL	MANUAL DE INSTALACIÓN Y USO	57
PORTUGUÊS	MANUAL DE USO E INSTALAÇÃO	75



To take full advantage of your EV charger, download the **BIAN.CO Easy** app for your smartphone:

Per sfruttare al massimo le potenzialità del tuo charger, scarica l'app **BIAN.CO Easy** sul tuo smartphone:

Pour tirer le meilleur parti de votre chargeur, téléchargez l'application **BIAN.CO Easy** sur votre smartphone :

Para aproveitar ao máximo as potencialidades do seu carregador, descarregue a aplicação **BIAN.CO Easy** para o seu smartphone:

Para aprovechar al máximo el potencial de tu cargador, descarga la app **BIAN.CO Easy** en tu smartphone:



• Conventions and symbols used in this document

- In the following, in this manual, the "charging station" is defined as "EV charger".
- Please view the symbols shown below used in this manual

Symbol	Meaning
	It highlights risks for people's health and safety and/or due to dangerous voltage with risk of electrocution.
	It highlights behaviors and precautions to pay attention to, the non-observance of which involves the risk of damage or malfunction
	Provides important tips for correct and optimal operation of the product

1. GENERAL INFORMATION

DLB Standard products

DLB (Dynamic Load Balancing) is an optional product available for BIAN.CO series EV chargers: it consists on a box that can be mounted on DIN rail or on a flat support and one or more openable current transformers (or simply "CT") that must be put on phase wires. When the EV charger is working with other household appliances at the same time, the DLB box can dynamically maintain the current absorption within a preset maximum value, avoiding EV charger causes overloads.

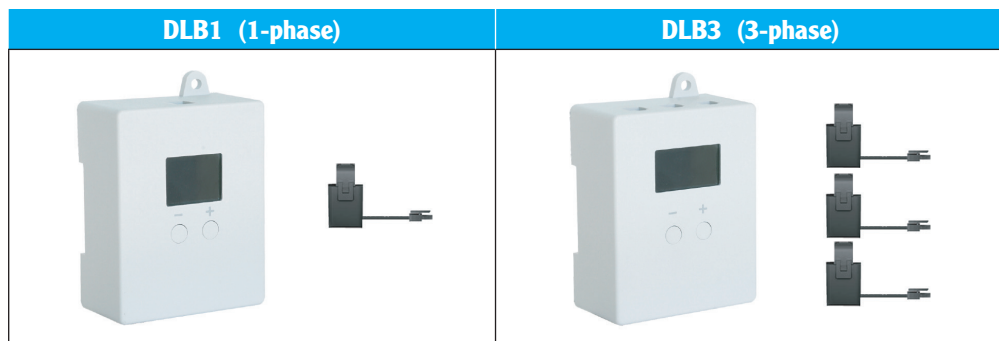

DLB-PV products

DLB-PV (Dynamic Load Balancing with photovoltaic integration) adds the photovoltaic power management to the Standard DLB model, controlling and managing power from PV according to different and selectable algorithms:

- **Full Speed:** mode Maximum and optimized use of both public grid and PV power
- **Only PV Mode:** only PV based power can be used for charging
- **Hybrid Mode:** maximum use of PV power, settable maximum use of public grid power

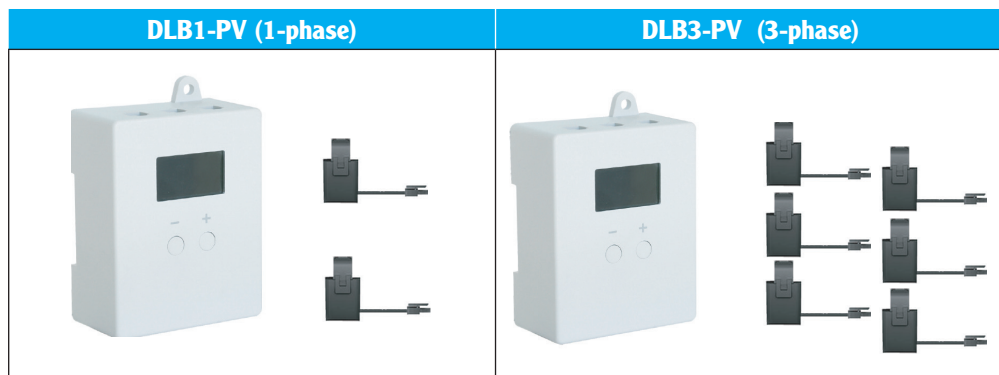

DLB-PV can also be used for the home without the photovoltaic power as standard DLB.

What is inside the box

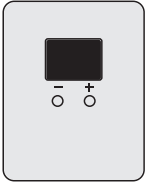

DLB Box
X1

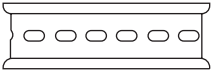

Din rail 105 mm
X1

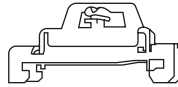

Din rail fixing parts
X2



M4x30 expansion screw
X2



Current Transformer (CT)
X1 (1-phase DLB1)
X3 (3-phase DLB3)
X2 (1-phase DLB1-PV)
X6 (3-phase DLB3-PV)



Network cable - 5m
(RJ45 TIA/EIA-568B 8-core cat5 twisted pair cables)
X1

2. STANDARD DLB PRODUCTS: SPECIFICATIONS AND INSTALLATION

Standard DLB specifications



Type	DLB1	DLB3
Installation	Single Phase	3-Phase
Dimensions / Weight	82x67x35 mm / 100 g	82x67x35 mm / 100 g
Extreme mode	yes	yes
Number of CT(s)	1	3
Display	7 segments LED	Graphic OLED
Maximum distance between DLB and EV charger	more than 200 m (standard 5 m network cable)	
CT cable length	1.5 m (can be customized up to 15 m)	
Installation	DIN rail installation/screw fixing	
Communication	RS485 (Use RJ45 interface to connect to EV charger)	



No extra power supply is needed, DLB Box is power supplied by the EV charger.

- **What is extreme mode:** in this mode, charging will be suspended once the home load keeps increasing to avoid home overload. Charging session will restart once there is ea minimum of 10A for charging.
DLB extreme mode can be enabled via BIAN.CO Easy app (see app manual for further details).

How standard DLB box works

For Single Phase DLB System (DLB1):

The current of EV Charger = max grid current (set on DLB Box) - household loads current

For Three Phase DLB System (DLB3):

The current of EV Charger = The minimum between:

Max grid current L1 Phase (set on DLB Box) - household loads current L1 Phase

Max grid current L2 Phase (set on DLB Box) - household loads current L2 Phase

Max grid current L3 Phase (set on DLB Box) - household loads current L3 Phase

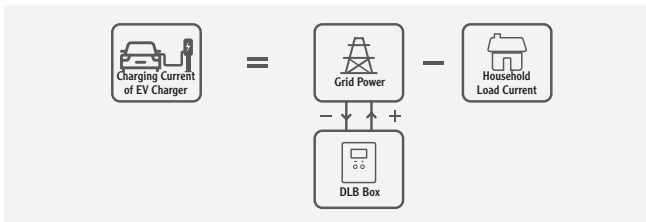

Multiple EV chargers

Assuming that when EV Charger ② starts charging, EV Charger ① is already charging:

EV Charge ① max. current = max grid current (set via DLB Box) - household load current

EV Charger ② max. current = max grid current (set via DLB Box) - household load current -

EV Charger ① .

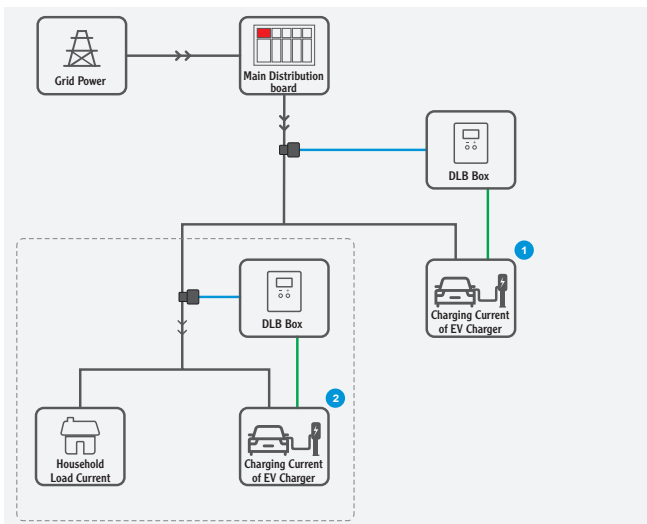

How to install the DLB Box



Installation of the CT clamp(s) requires the contact with electrical wires: it is strongly recommended to refer to qualified professional personnel for installation.



The wrong positioning or installation of the CT clamp(s) can impact on DLB functionality: please follow this manual for correct positioning and installation.



In DLB3 three phases version, the sequence of the phases must be the same as the EV Charger terminal block one. Phase inversion can generate DLB3 malfunctions.

STEP 1 - Current Transformer (CT) installation

- Open and connect the current transformer(s) CT clamp(s), according to one of the following cases.

case 1 - Household Load and EV charger lines in parallel

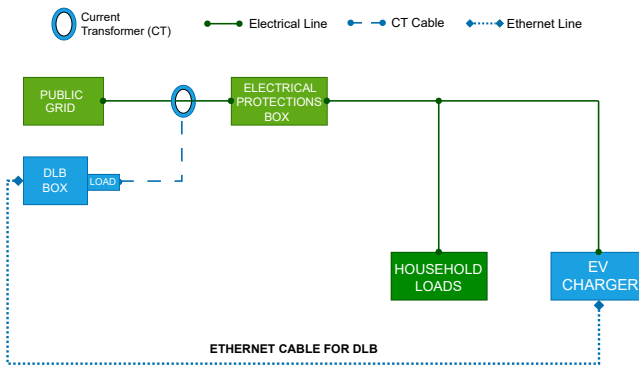

case 2 - Household Load and EV charger lines in series

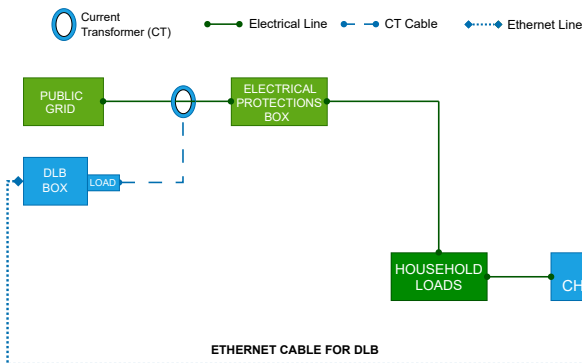

case 3 - PV plant presence with a non PV DLB model

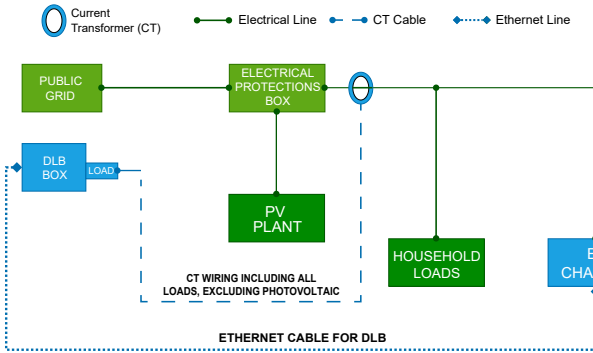

! These wiring schemas are applicable to DLB1 and DLB3 only; please refer to next pages for DLB1-PV and DLB3-PV.

- For single-phase DLB1 onto the phase conductor of the main cable, (see Figure) positioning it next to provider energy meter.
- For three-phase DLB3, onto the 3 phases conductors of the main cables (see Figure), one on each phase, positioning them next to Provider energy meter.
- Connect all CT clamps cable to the DLB box: the presence of cable connector helps connecting them correctly and prevents loose cabling.

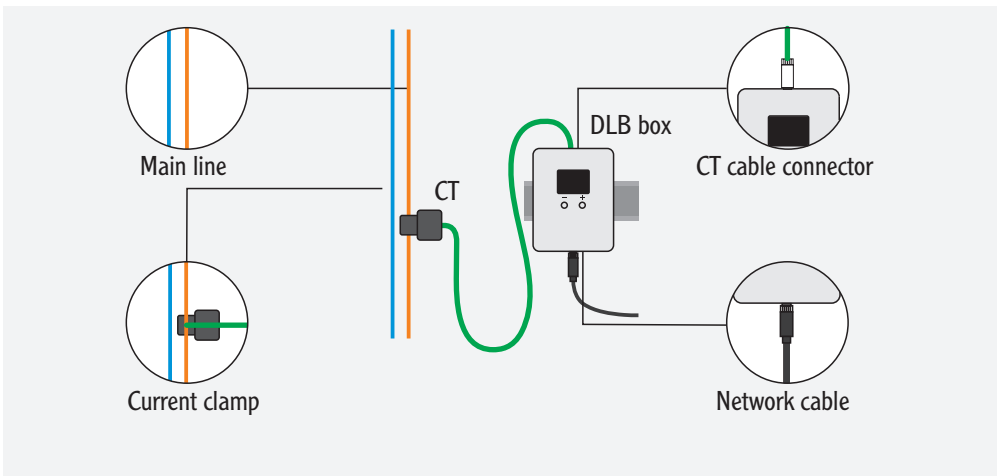
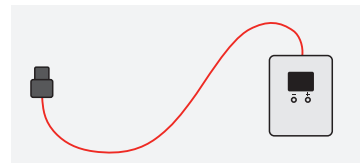
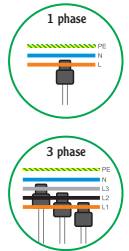

STEP 2 - Network cable connection

Connect the DLB box to the charger via network cable: this cable brings both power supply and communication to the DLB Box.

Procedure:

1. Switch off the main power supply of the EV charger.
2. Open EV charger front panel.
3. Bring one network cable head inside the EV charger.
4. Find the ethernet port on the main electronic board of the EV charger (see image) and connect the network cable to it.
5. Reinstall the EV Charger front panel and switch on the main power supply again.
6. Connect the other network cable head to the lower part of DLB Box: if the DLB Box switches on, you can proceed to the next steps.
7. Reboot the EV Charger by switching mains protections off and, after 5 seconds, on again.

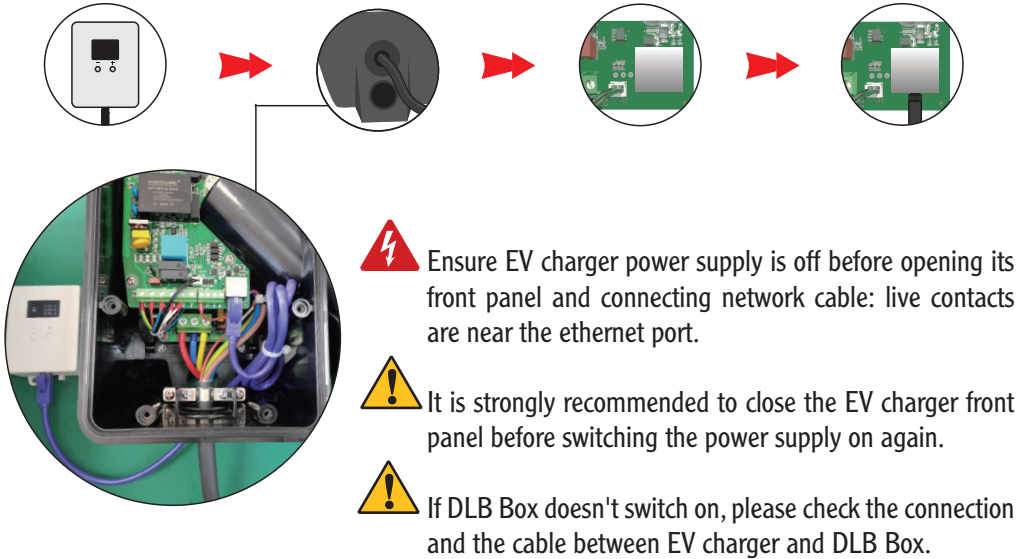

Recommended network cable

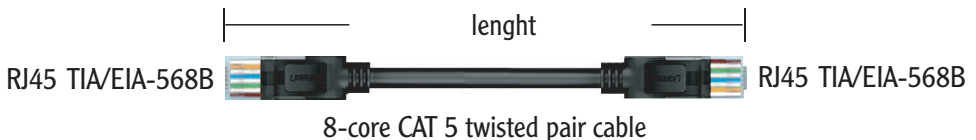

How to set the maximum grid current on Standard DLB Box

- Single Phase DLB Box



Current measured

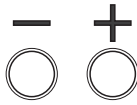

Press any button

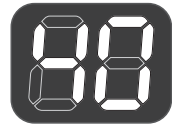

Set value

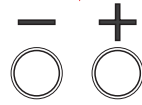

Press "+", "-" to adjust the value

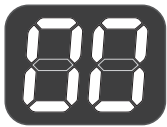

Current measured



Wait for 5 s till automatic set



Set value



In order to let DLB Box work correctly, maximum current must be set lower than (or equal to) the maximum grid one





In case the maximum grid current changes, don't forget to change it also on DLB Box

DLB Troubleshooting

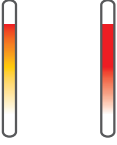

All the troubleshooting activities that include cables check and/or EV charger opening must be done by a qualified professional: self-check or repair may result risky in terms of electrical safety.

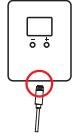
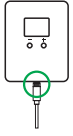
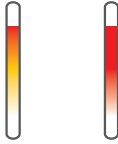
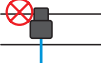
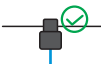
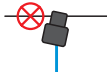
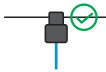
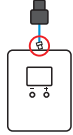
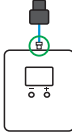
LED Light charger status	Fault Type	Potential Cause	Solution
 <p>Continuous sequence of yellow and red LEDs flashes on EV charger</p>	DLB offline	 <p>Ethernet cable is damaged</p>	 <p>Replace Ethernet cable</p>
		 <p>Ethernet cable is not connected firmly</p>	 <p>Reconnect</p>
 <p>Continuous sequence of single yellow LED flash, followed by double red LED flashes.</p>	DLB current measurement fault	 <p>CT is clamped on the wrong power cord</p>	 <p>Check if the CT position is correct</p>
		 <p>CT open coil is not connected firmly</p>	 <p>Reconnect</p>
		 <p>The connection between the CT cable and the DLB is loose</p>	 <p>Reconnect</p>
		<p>The DLB box doesn't measure the charging current</p>	<p>Check if the CT position is correct</p>

DLB-PV characteristics



Type	DLB1-PV	DLB3-PV
Installation	Single Phase	3-Phase
Dimensions / Weight	82x67x35 mm / 100 g	82x67x35 mm / 100 g
"PV Extreme" mode	√	√
PV to Normal /Normal to PV	√	√
Night Automatic Full Speed Mode	√	√
Number of supplied CT(s)	2	6
Display	Graphic OLED	Graphic OLED
Maximum distance between DLB and EV charger	more than 300 m (standard 5 m network cable)	
CT cable Length	1.5 m (can be customized up to 15 m)	
Installation	DIN rail installation/screw fixing	
Communication	RS485 (Use RJ45 interface to connect with network)	

i No extra power supply is needed, DLB is power supplied by the EV charger.

- What is Extreme Mode:** in this mode, once the household load keeps increasing and the PV power generation isn't enough to maintain the EV charger's minimum current, it will suspend charging to avoid overload. Charging session will restart once there is a minimum of 10A for charging. DLB extreme mode can be enabled via BIAN.CO Easy app (see app manual for further details).
- What is Night Automatic Full Speed Mode:** in this mode, EV charger keeps charging at full speed (08:00 pm - 06:00 am). Night Automatic Full Speed Mode can be enabled and set via BIAN.CO Easy app (see app manual for further details)

How DLB-PV works

For Single Phase System (DLB1-PV):

Maximum current of EV Charger = Max grid current + PV power current - household load current.

For 3-Phase System (DLB3-PV):

Maximum current of EV Charger = Max grid current + (PV power current - household load current) / 3.

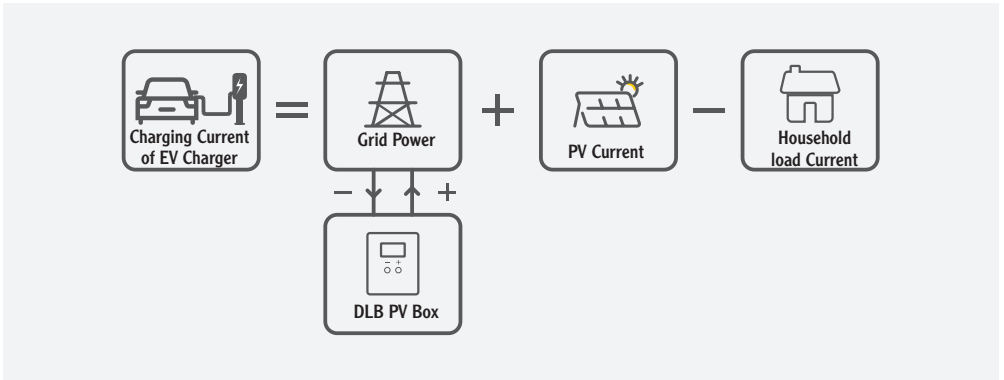

How to install DLB-PV

Open and connect the current transformer(s) CT clamp(s), according to one of the following cases.

case 1 - Household Load and EV charger lines in parallel

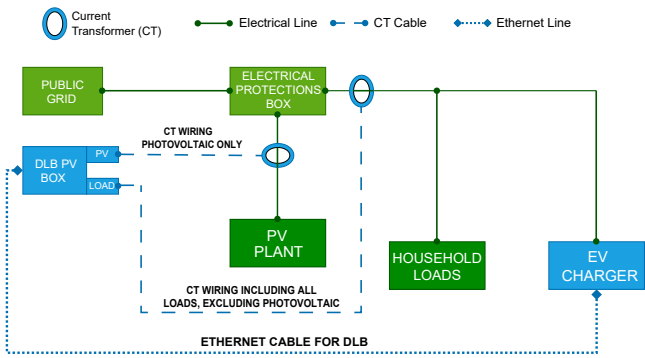

case 2 - Household Load and EV charger lines in series

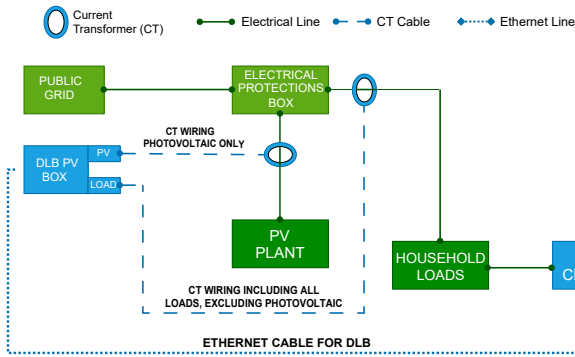

As for Standard DLB Box, CT(s) installation on PV line requires the potential contact with electrical parts: only qualified professionals are allowed to operate in such conditions.



In order to operate in safety conditions, we strongly suggest to switch PV inverter off before installing CT(s) on PV line wires.

Charging algorithm	Description
<p>Only PV Mode</p> <p>Only PV Mode</p>	<p>The EV charger in Only PV Mode automatically adjusts the maximum charging current, with the aim to keep the charging current request coming from grid near to zero.</p>
<p>Hybrid Mode</p> <p>Hybrid Mode 10A</p>	<p>The EV charger in Hybrid Mode automatically adjusts the maximum charging current, with the aim to limit the charging current from grid within a settable value.</p>
<p>Full Speed Mode</p> <p>Full Speed Mode</p>	<p>When the EV charger is working in Full Speed Mode, it automatically adjusts the maximum current in order to always provide the maximum power available to the electric vehicle, without distinguishing PV from grid.</p>

How to switchover PV to Standard DLB

 This procedure can be applied only to DLB-PV

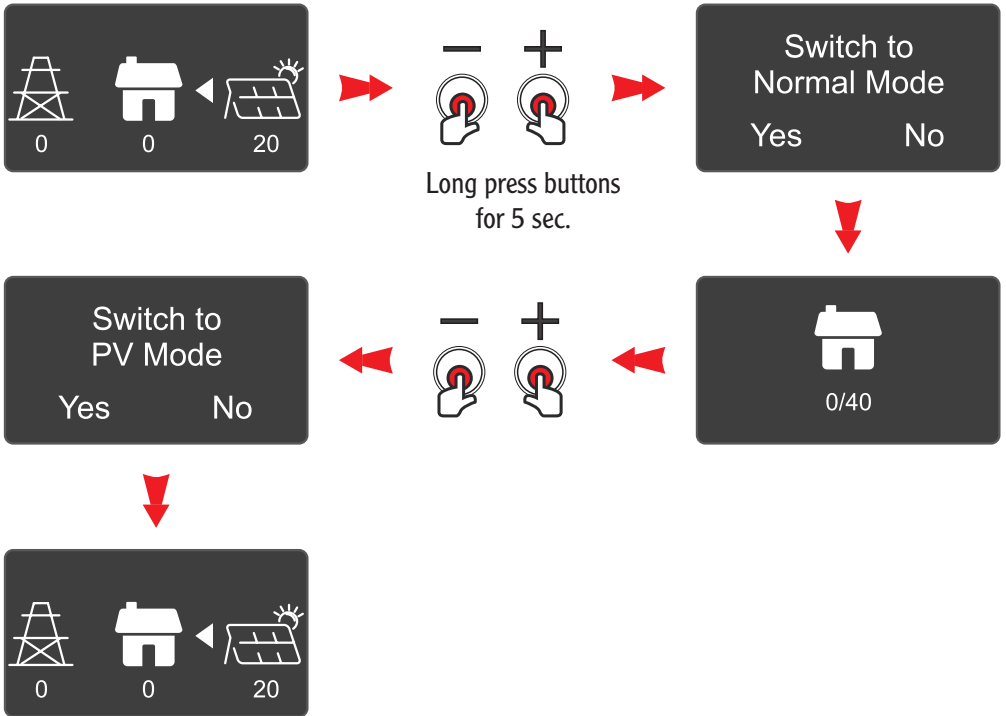

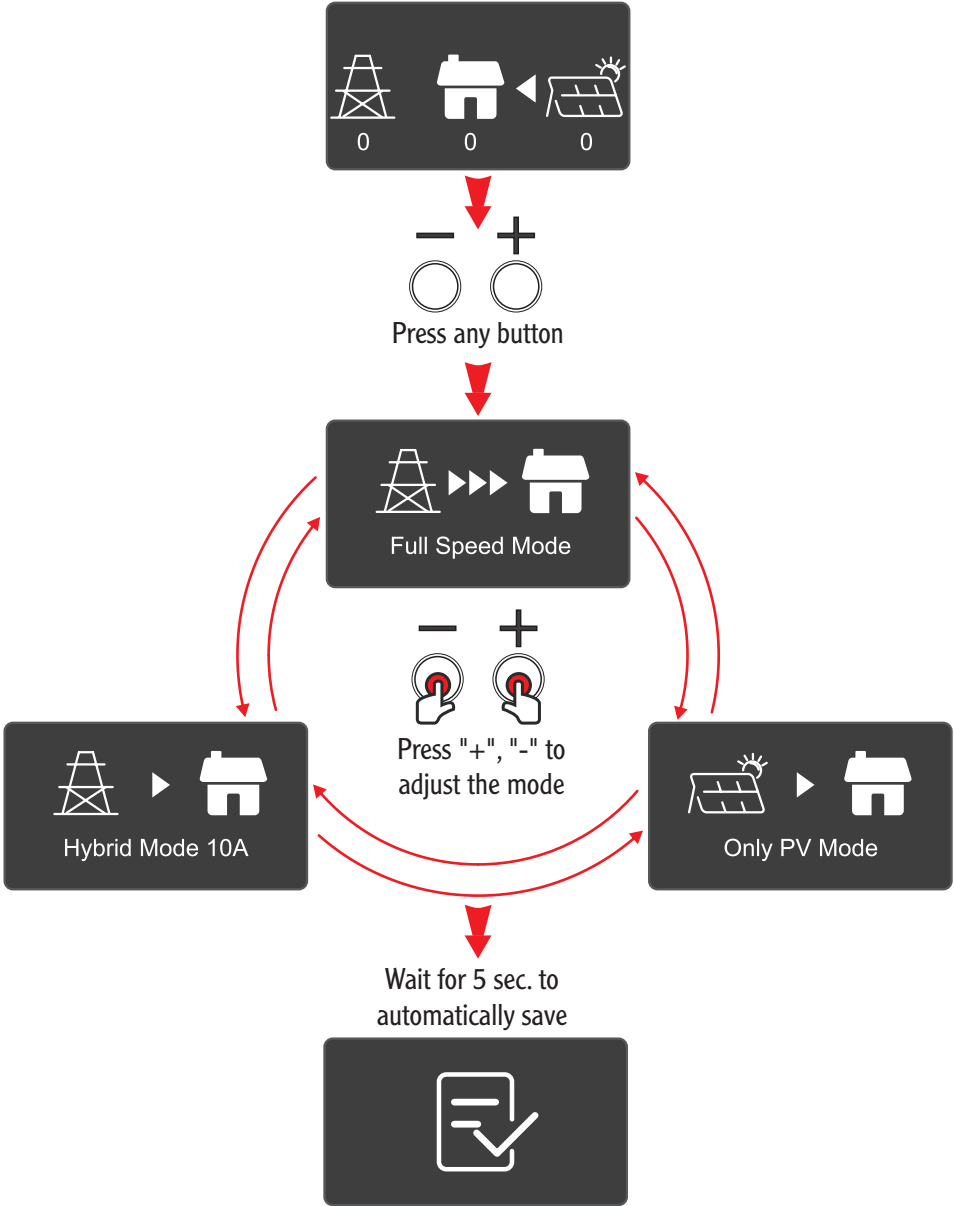

How to switchover between algorithms provided by DLB-PV



DLB-PV Troubleshooting

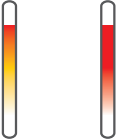

All the troubleshooting activities that include cables check and/or EV charger opening must be done by a qualified professional: self-check or repair may result risky in terms of electrical safety.

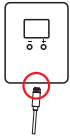
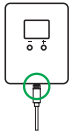
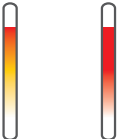
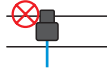
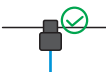
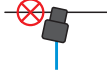
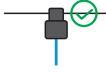
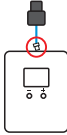
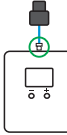
LED Light charger status	Fault Type	Potential Cause	Solution
 <p>Continuous sequence of yellow and red LEDs flashes on EV charger</p>	DLB offline	 <p>Ethernet cable is damaged</p>	 <p>Replace Ethernet cable</p>
		 <p>Ethernet cable is not connected firmly</p>	 <p>Reconnect</p>
 <p>Continuous sequence of single yellow LED flash, followed by double red LED flashes.</p>	DLB current measurement fault	 <p>CT is clamped on the wrong power cord</p>	 <p>Check if the CT position is correct</p>
		 <p>CT open coil is not connected firmly</p>	 <p>Reconnect</p>
		 <p>The connection between the CT cable and the DLB is loose</p>	 <p>Reconnect</p>
		<p>The DLB box doesn't measure the charging current</p>	<p>Check if the CT position is correct</p>

– Following information applies in member states of the European Union:



USER INFORMATION in accordance with Directive 2012/19/EU.

The ‘Not in the bin’ symbol above when shown on equipment or packaging means that the equipment must, at the end of its life, be disposed of separately from other waste.

The separate waste collection of such equipment is organised and managed by the manufacturer. Users wishing to dispose of such equipment must contact the manufacturer and follow the prescribed guidelines for its separate collection. Appropriate waste separation, collection, environmentally compatible treatment and disposal is intended to reduce harmful environmental effects and promote the reuse and recycling of materials contained in the equipment. Unlawful disposal of such equipment will be subject to the application of administrative sanctions provided by current legislation.

Warranty description

- Product warranty is valid for two years from the purchasing date: it protects against damages and/or failure due to product quality issues or defects.
- The warranty does not cover any damage caused by malfunction, natural events, installation or maintenance performed improperly or by unqualified parties, use contrary to instructions, normal tear and wear. In any case, the warranty does not cover any economic damages resulting from inability to use the product or failure to charge the vehicle or vehicle faults.
- Product installation and maintenance should be executed exclusively by professionals, that certify "workmanlike manner" installation and safety.
- The warranty terms and conditions for CEMBRE products are shown on the website www.cembre.com, within the general terms and conditions of sale.
- In event of failure, malfunction or fault during normal use, please stop using the product and avoid self-repair: call your installer to restore product and installation properly.

Note: CEMBRE reserves the right to update the contents of this manual without notice and at any time. Please refer to the QR code included in the packaging to check for updates.

1. INFORMAZIONI GENERALI

Modulo DLB Standard

I charger serie BIAN.CO possono essere dotati di dispositivo DLB (Dynamic Load Balancing) per il bilanciamento dinamico del carico elettrico. Consiste di un modulo installabile su guida DIN o su supporto piatto e da uno o più trasformatori amperometrici (o "CT") apribili, da attestare sui conduttori di fase: quando sulla linea del charger sono presenti anche altri carichi, il DLB è in grado di limitare automaticamente l'assorbimento totale di corrente del charger, al fine di non rendere il sistema di ricarica la causa primaria di un sovraccarico della linea di alimentazione.

DLB1 (monofase)

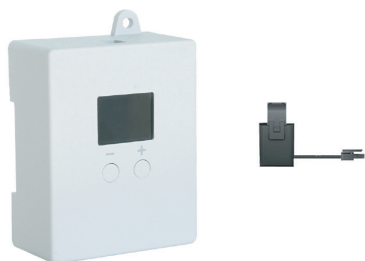

DLB3 (trifase)

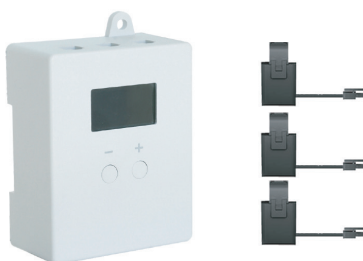

Modulo DLB-PV (per fotovoltaico)

Il DLB-PV permette di integrare un impianto fotovoltaico: oltre alle funzionalità del DLB di tipo Standard, il DLB-PV è in grado di sfruttare l'apporto dato dall'impianto fotovoltaico, ottimizzando e/o massimizzando l'erogazione secondo diverse modalità:

- **Full Speed Mode** sfrutta sia energia fornita dalla linea di alimentazione che del fotovoltaico
- **Only PV Mode** sfrutta solo l'energia prodotta dall'impianto fotovoltaico
- **Modalità ibrida** (massimizza l'erogazione sfruttando il fotovoltaico e una quantità massima di alimentazione di rete impostabile)



DLB1-PV (monofase)

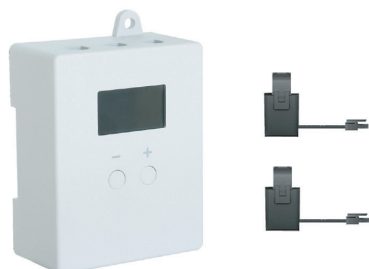

DLB3-PV (trifase)

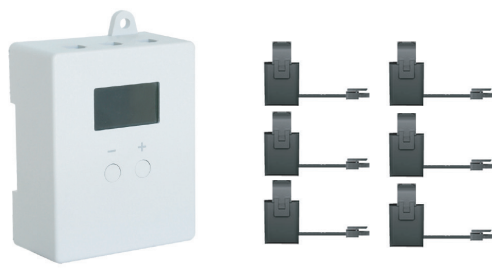

Il DLB-PV può essere utilizzato anche come DLB standard senza integrazione del fotovoltaico.

Nella confezione:

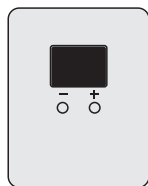

Dispositivo DLB
X1

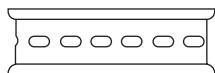

Guida Din 105 mm

X1

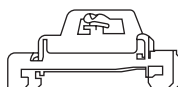

Particolari per fissaggio guida Din

X2



Vite a espansione
M4x30

X2



Trasformatore di corrente (CT)

X1 (DLB monofase)

X3 (DLB3 trifase)

X2 (DLB-PV monofase)

X6 (DLB3-PV trifase)





Cavo di rete - 5 m
(cavo RJ45 TIA/EIA-568B cat5 a 8 conduttori)

X1

2. DLB STANDARD: SPECIFICHE ED INSTALLAZIONE

Specifiche DLB standard

		
Tipo	DLB1	DLB3
Installazione	monofase	trifase
Dimensioni / Peso	82x67x35 mm / 100 g	82x67x35 mm / 100 g
Modalità "Extreme"	√	√
standard a fotovoltaico / Fotovoltaico a standard	-	-
Modalità Night Automatic Full Speed	-	-
Trasformatori di corrente a corredo	1	3
Display	LED, a segmenti	OLED, grafico
Connessione tra DLB e charger	entro 300 m (cavo di rete standard da 5 m)	
Lunghezza standard cavo CT	1,5 m (personalizzabile fino a 15 m)	
Installazione	Installazione su guida DIN / fissaggio a vite	
Comunicazione	RS485 (a mezzo cavo ethernet)	

i Non è necessario alcun alimentatore aggiuntivo: il box DLB viene alimentato dal charger via ethernet.

- **Che cos'è la modalità "Extreme":** in questa modalità, se la corrente richiesta dai carichi domestici continua ad aumentare, la ricarica viene sospesa per evitare il sovraccarico. La ricarica riprende quando torna ad essere disponibile una corrente di almeno 10 A. La modalità DLB Extreme si può attivare tramite app BIAN.CO Easy (per le modalità di attivazione, far riferimento al manuale dedicato).

Come funziona il dispositivo DLB

Per sistema DLB monofase (DLB1):

Corrente del charger = corrente massima di rete (impostata su DLB) - Corrente di carico domestico

Per il sistema DLB trifase (DLB3):

Corrente del charger = la minore tra:

corrente massima di rete fase L1 (impostata su DLB) - Corrente di carico domestico fase L1

corrente massima di rete fase L2 (impostata su DLB) - Corrente di carico domestico fase L2

corrente massima di rete fase L3 (impostata su DLB) - Corrente di carico domestico fase L3

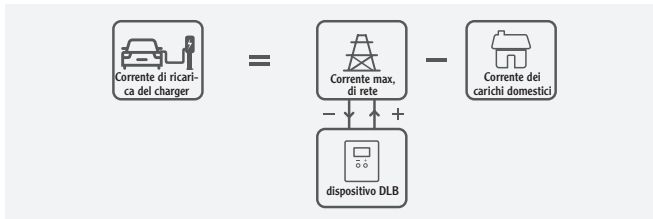

Stazioni di ricarica multiple

Ipotizzando la condizione che, al momento in cui il Charger **2** inizia una sessione di ricarica, il Charger **1** stia già ricaricando un veicolo:

- Corrente massima Charger **1** = Corrente massima di rete (impostata su DLB) - Corrente di carico domestico

- Corrente massima Charger **2** = Corrente massima di rete (impostata su DLB) - Corrente di carico domestico - Charger **1**.

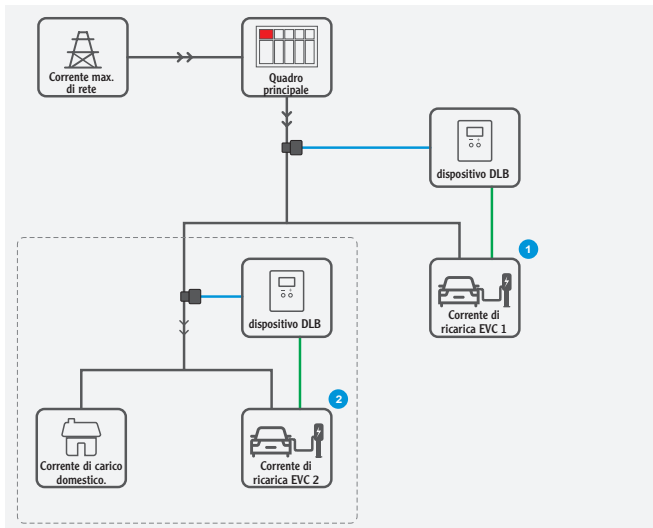

Come installare il dispositivo DLB

 L'installazione dei CT richiede il contatto con conduttori potenzialmente in tensione: l'attività di installazione deve essere eseguita pertanto da personale qualificato e professionista.

 Il posizionamento errato dei CT provoca il malfunzionamento del DLB: attenersi scrupolosamente alle istruzioni fornite in questo manuale.

 Nella versione trifase DLB3, la sequenza delle fasi deve essere rispettata e deve essere la stessa utilizzata per il charger. Inversioni di fase possono generare malfunzionamenti al sistema DLB.

STEP 1 - Installazione del trasformatore di corrente (CT)

- Aprire e collegare il/i morsetto/i CT del/i trasformatore/i di corrente, secondo uno dei seguenti casi.

caso 1 - Linee di carico domestico ed EV Charger in parallelo

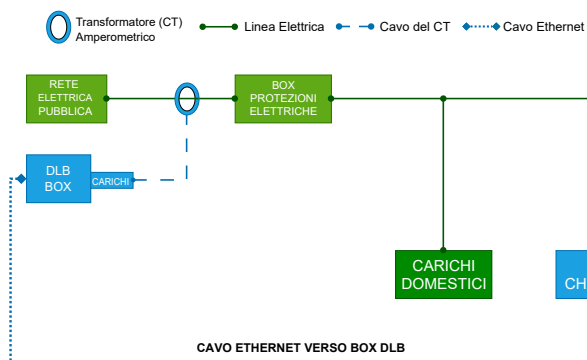

CASO 2 - Linee di carico domestico ed EV Charger in serie

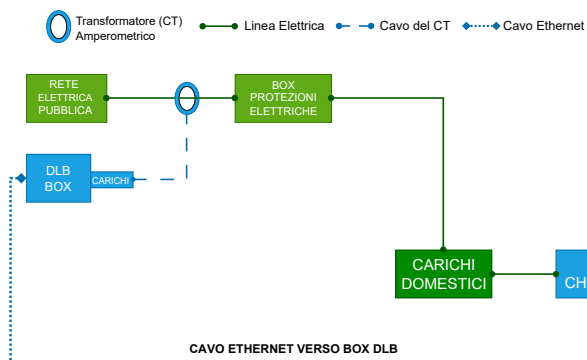

CASO 3 - Impianto con fotovoltaico e Standard DLB BOX (non versione DLB-PV)

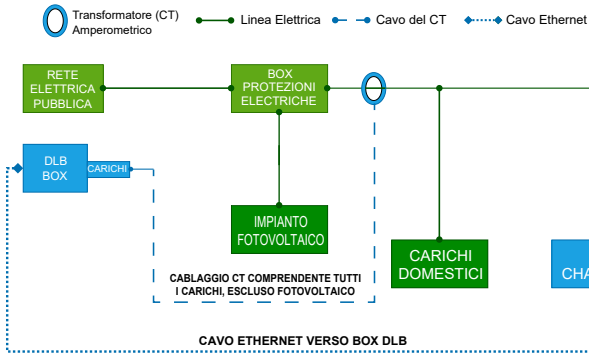

! Questi schemi di cablaggio sono applicabili solo a DLB1 e DLB3; per DLB1-PV e DLB3-PV fare riferimento alle pagine successive.

- Nel caso di DLB monofase, collegare il CT sul conduttore di fase della rete (vedi figura).

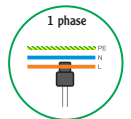

- Nel caso di DLB3 trifase, collegare i tre CT, uno su ogni fase (vedi figura).

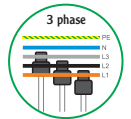

- Collegare correttamente i cavi dei CT al dispositivo DLB: la presenza di connettori in testa al cavo di ciascun CT agevola e rende più stabile il collegamento al DLB.

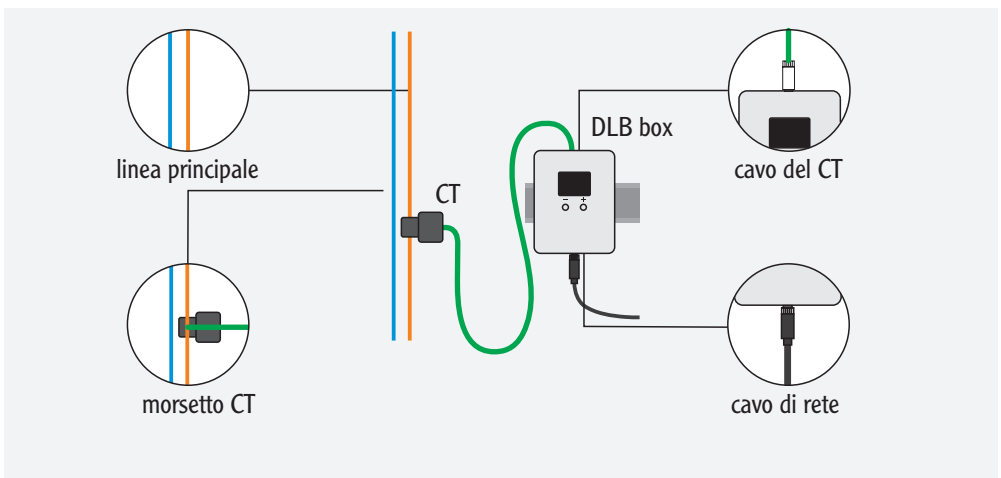
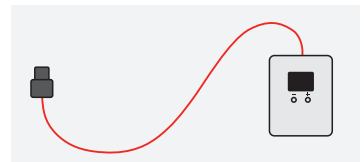

STEP 2 - Collegamento al charger tramite cavo di rete

Collegare il dispositivo DLB al charger tramite il cavo di rete: questo cavo trasporta sia l'alimentazione sia i dati di comunicazione tra il charger e il dispositivo DLB.

Procedura:

1. Interrompere la linea di alimentazione del charger.
2. Rimuovere il pannello frontale del charger.
3. Inserire il cavo ethernet all'interno del charger, le modalità possibili di ingresso cavo sono riportate nel manuale di installazione del charger.
4. Identificare la porta ethernet sulla scheda elettronica (vedi figura) e collegarvi il cavo ethernet.
5. Riposizionare il pannello frontale del charger e riattivare la linea di alimentazione.
6. Connettere l'altro capo del cavo ethernet sul lato inferiore del DLB, se il box DLB si avvia, è possibile procedere con i passi successivi.
7. Riavviare il charger: è sufficiente togliere l'alimentazione per 5 secondi e ri-alimentare.

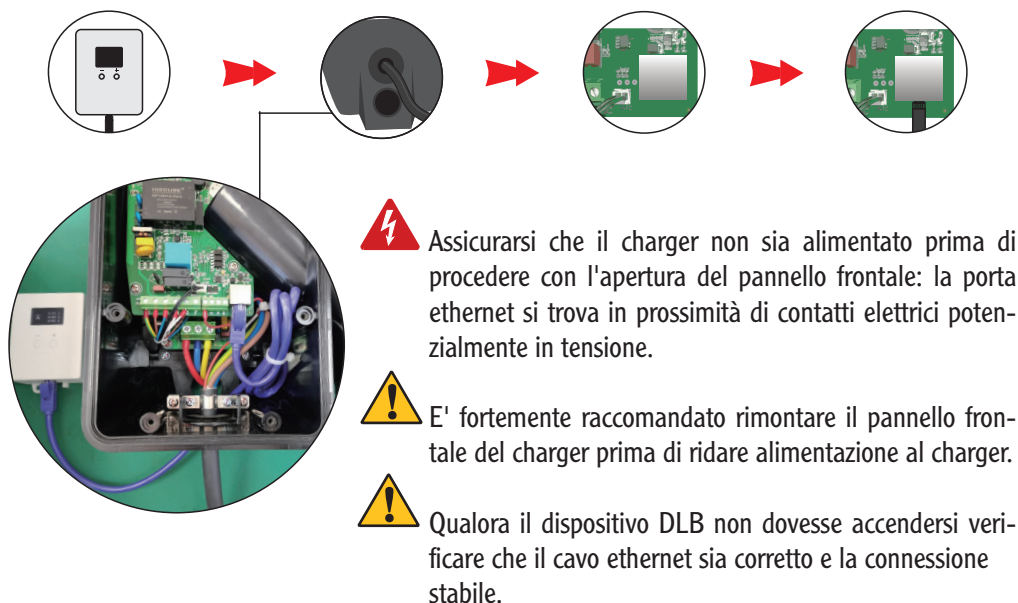

Cavo di rete raccomandato

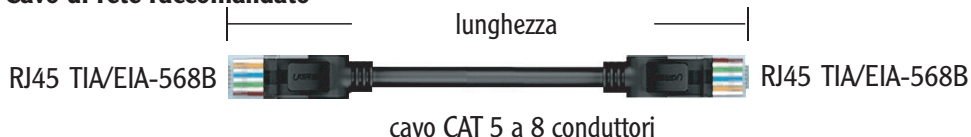

Come impostare la massima corrente di rete sul dispositivo DLB standard

- Dispositivo monofase DLB1



Corrente misurata

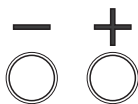

Premere un
pulsante qualsiasi



Valore impostato

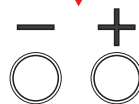

Premere "+" o "-"
per regolare il valore



Valore impostato



Attendere 5 s fino
al salvataggio
automatico

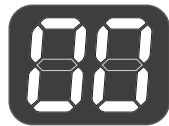

Corrente misurata



Al fine di poter operare correttamente, la massima corrente di funzionamento deve essere impostata ad un valore inferiore o uguale alla corrente di rete disponibile da contratto con l'ente distributore.



In caso di variazioni contrattuali con l'ente distributore che implicino un cambio di potenza massima e quindi di corrente, è indispensabile aggiornare anche l'impostazione di corrente massima del DLB.

- Dispositivo trifase DLB3

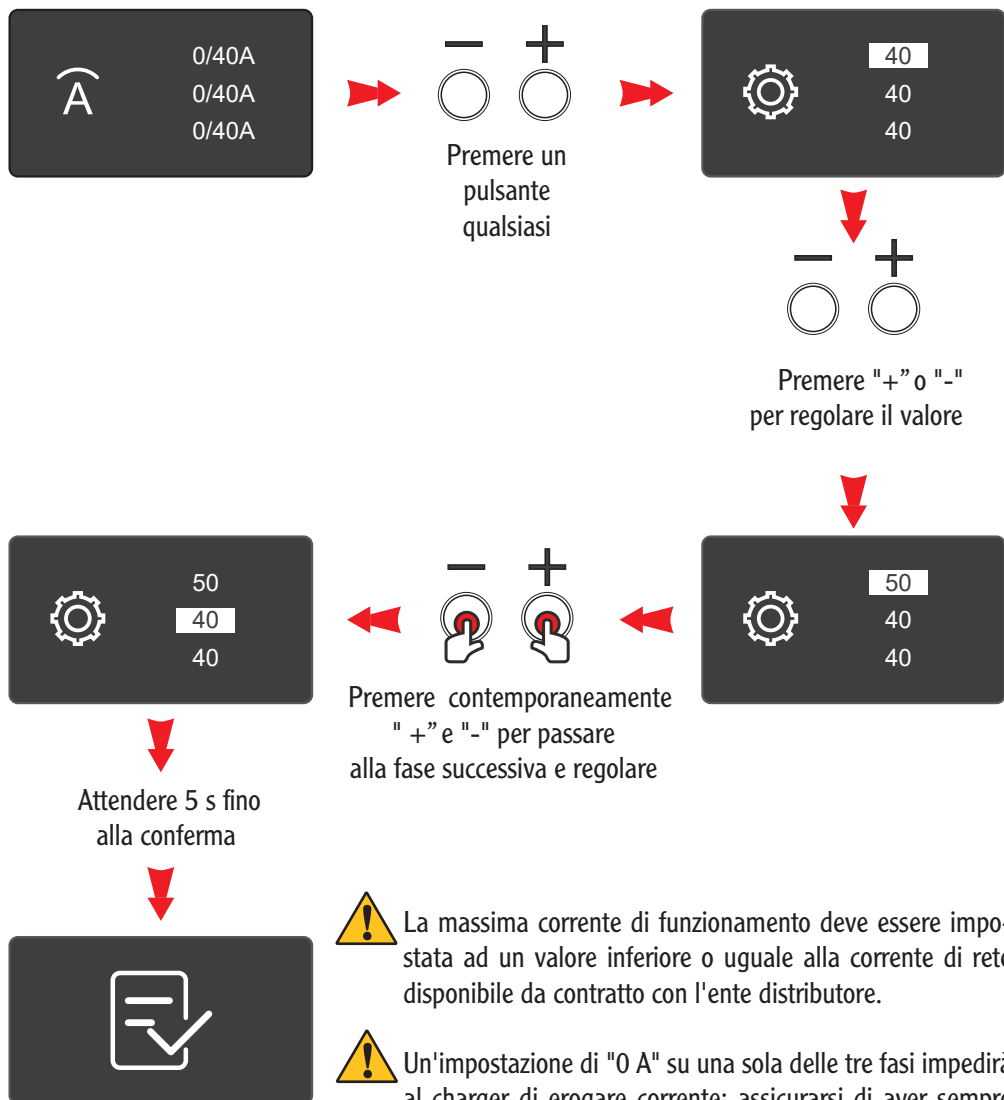

La massima corrente di funzionamento deve essere impostata ad un valore inferiore o uguale alla corrente di rete disponibile da contratto con l'ente distributore.



Un'impostazione di "0 A" su una sola delle tre fasi impedirà al charger di erogare corrente: assicurarsi di aver sempre impostato i parametri corretti per ogni fase.







In caso di variazioni contrattuali con l'ente distributore che implicino un cambio di potenza massima e quindi di corrente, è indispensabile aggiornare anche l'impostazione di corrente massima del DLB.

Risoluzione problemi per DLB standard

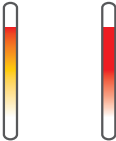

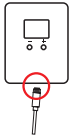
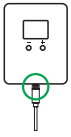
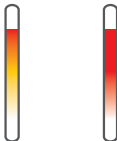
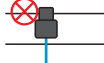
Qualsiasi operazione di controllo e/o riparazione deve essere svolta da personale qualificato. Le riparazioni e verifiche effettuate in autonomia sono ad alto rischio elettrico.

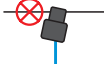
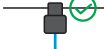
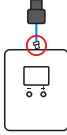
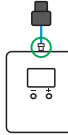
Stato della luce LED sul charger	Tipo di guasto	Possibile causa	Soluzione
 <p data-bbox="225 373 451 456">Sequenza continua di LED giallo e LED rosso, a intermittenza</p>	DLB offline	 <p data-bbox="692 405 813 459">Cavo ethernet danneggiato</p>	 <p data-bbox="893 405 1033 459">Sostituire il cavo ethernet</p>
		 <p data-bbox="647 624 857 678">Cavo ethernet non collegato in modo corretto</p>	 <p data-bbox="911 624 1009 647">Ricollegare</p>
 <p data-bbox="244 863 451 975">Un lampeggio del LED giallo seguito da due lampeggi del LED rosso, a ripetizione</p>	Anomalia nella misura della corrente del DLB	 <p data-bbox="658 767 846 852">Il CT è agganciato sul cavo di alimentazione sbagliato</p>	 <p data-bbox="889 767 1031 852">Verificare che la posizione del CT sia corretta</p>
		 <p data-bbox="658 943 846 1027">Il morsetto del CT è aperto non è collegato in modo stabile</p>	 <p data-bbox="911 967 1009 991">Ricollegare</p>
		 <p data-bbox="669 1198 835 1283">Il collegamento tra il cavo del CT e il DLB è instabile</p>	 <p data-bbox="911 1198 1009 1222">Ricollegare</p>
		<p data-bbox="658 1310 846 1394">Il dispositivo DLB non misura la corrente di carica del charger</p>	<p data-bbox="889 1310 1031 1394">Verificare che la posizione del CT sia corretta</p>

3. DLB-PV: SPECIFICHE E INSTALLAZIONE

Caratteristiche dei DLB-PV, per impianti fotovoltaici



Tipo	DLB1-PV	DLB3-PV
Installazione	monofase	trifase
Dimensioni / Peso	82x67x35 mm / 100 g	82x67x35 mm / 100 g
Modalità "PV Extreme"	√	√
Possibilità di funzionamento senza fotovoltaico	√	√
Modalità Night Automatic Full Speed	√	√
Trasformatori di corrente CT in dotazione	2	6
Display	OLED, grafico	OLED, grafico
Connessione tra DLB e charger	entro 300 m (cavo di rete standard da 5 m)	
Lunghezza del cavo del singolo CT	1,5 m (personalizzabile fino a 15 m)	
Installazione	Installazione su guida DIN / fissaggio a vite	
Comunicazione	RS485 (a mezzo cavo ethernet)	

i Non è necessario alcun alimentatore aggiuntivo: il DLB viene alimentato dal charger via ethernet

- **Cos'è la modalità "Extreme":** in questa modalità, se la corrente richiesta dai carichi domestici continua ad aumentare e l'energia fornita dall'impianto fotovoltaico non è sufficiente a mantenere la corrente minima del charger, la ricarica viene interrotta per evitare un sovraccarico. La ricarica viene riavviata automaticamente quando la disponibilità di corrente sulla linea è pari o maggiore a 10A. Tale modalità si può attivare tramite la app BIAN.CO Easy (per dettagli consultare il manuale).
- **Cos'è la modalità "Night Automatic Full Speed":** in questa modalità, il charger continua a ricaricare il veicolo elettrico alla massima velocità possibile dalle 20:00 alle 06:00. Tale modalità si può configurare e attivare tramite la app BIAN.CO Easy (per dettagli consultare il manuale).

Come funziona il dispositivo DLB-PV per fotovoltaico

DLB1-PV per il sistema monofase:

Corrente del charger = Corrente massima di rete + Corrente Fotovoltaico - Corrente dei carichi domestici

DLB3-PV per il sistema trifase:

Corrente del charger = Corrente massima di rete + (Corrente Fotovoltaico - Corrente dei carichi domestici) / 3

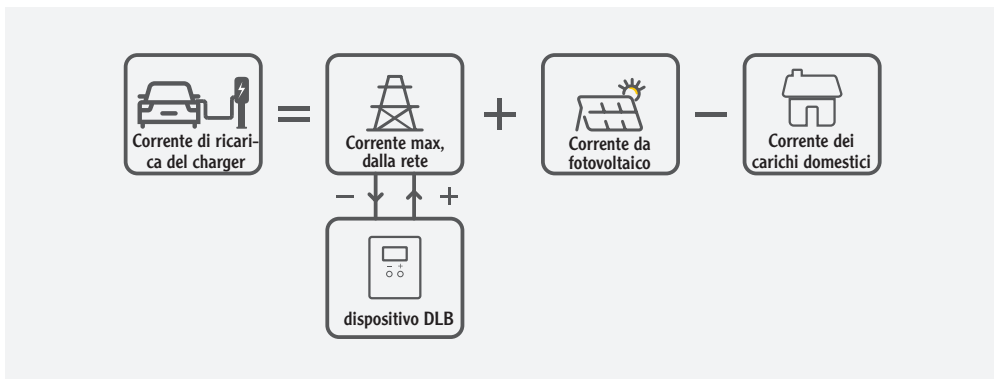

Come installare il dispositivo DLB-PV per fotovoltaico

Aprire e collegare il/i morsetto/i CT del/i trasformatore/i di corrente, secondo uno dei seguenti casi.

caso 1 - Linee di carichi domestici ed EV Charger in parallelo

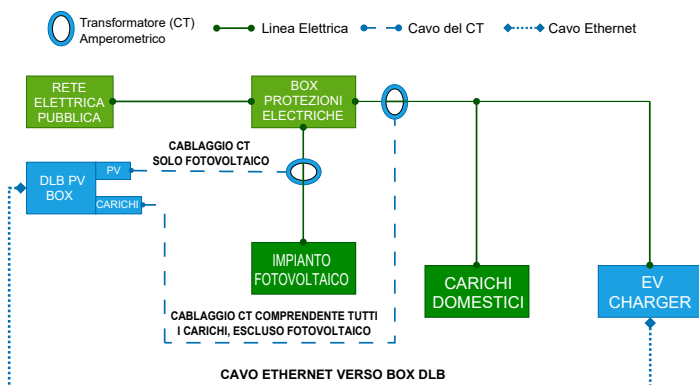

caso 2 - Linee di carichi domestici ed EV charger in serie

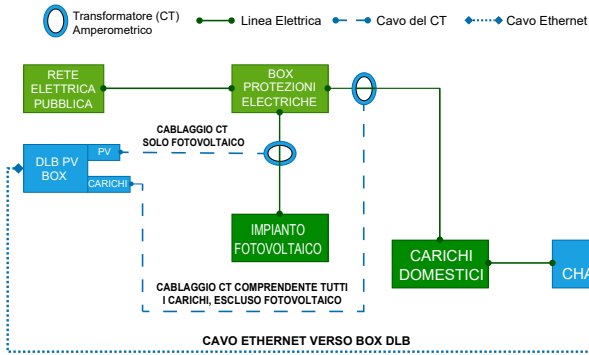

Come per il DLB Standard, l'installazione dei CT richiede personale qualificato in quanto potenzialmente a contatto con parti in tensione.



Per operare in condizioni di sicurezza, si consiglia di interrompere l'alimentazione dell'inverter dell'impianto fotovoltaico prima di posizionare i relativi CT.

Quali algoritmi sono applicabili al DLB-PV

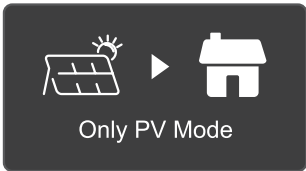
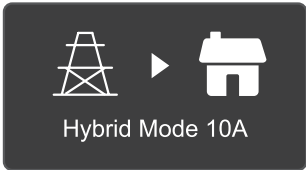
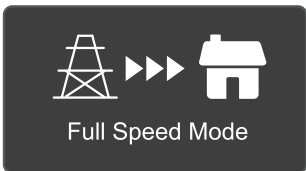
Algoritmo di ricarica	funzionamento
Only PV  Only PV Mode	Il charger in modalità "Only PV" modula automaticamente la massima corrente di ricarica, al fine di non richiedere extra corrente alla rete pubblica
Hybrid  Hybrid Mode 10A	Il charger in modalità "Hybrid" modula automaticamente la massima corrente di ricarica, al fine di non assorbire mai dalla rete una quantità di corrente superiore a quella impostata
Full Speed  Full Speed Mode	Il charger in modalità "Full Speed" modula automaticamente la massima corrente di ricarica al fine di massimizzare la potenza erogata, in funzione di quella totale disponibile

Come passare da PV a Standard (solo per versioni DLB-PV)

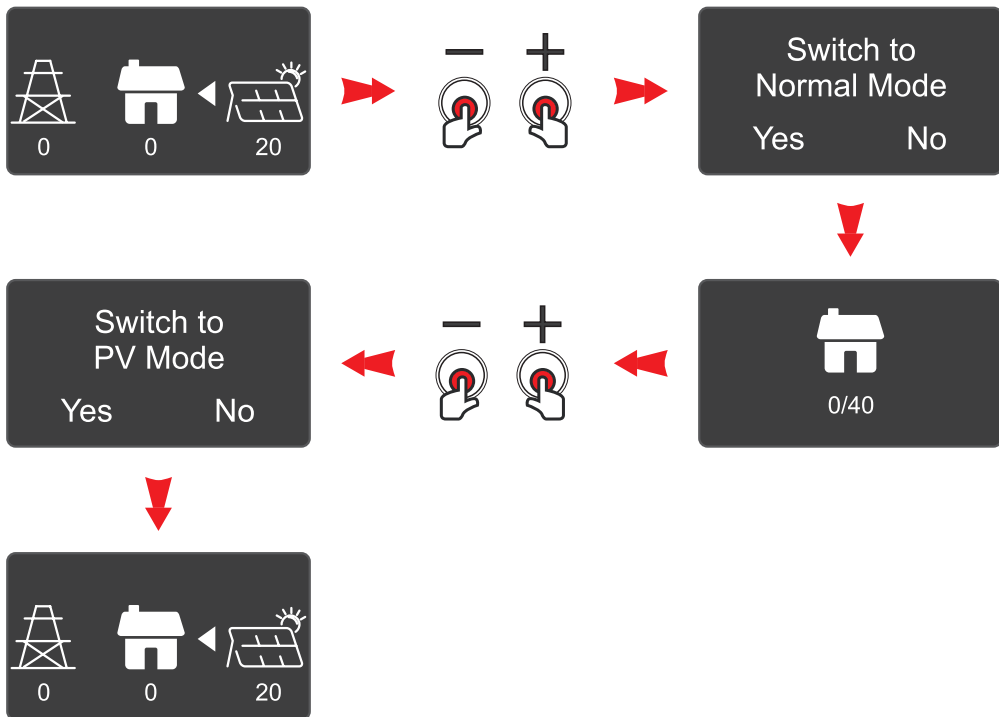



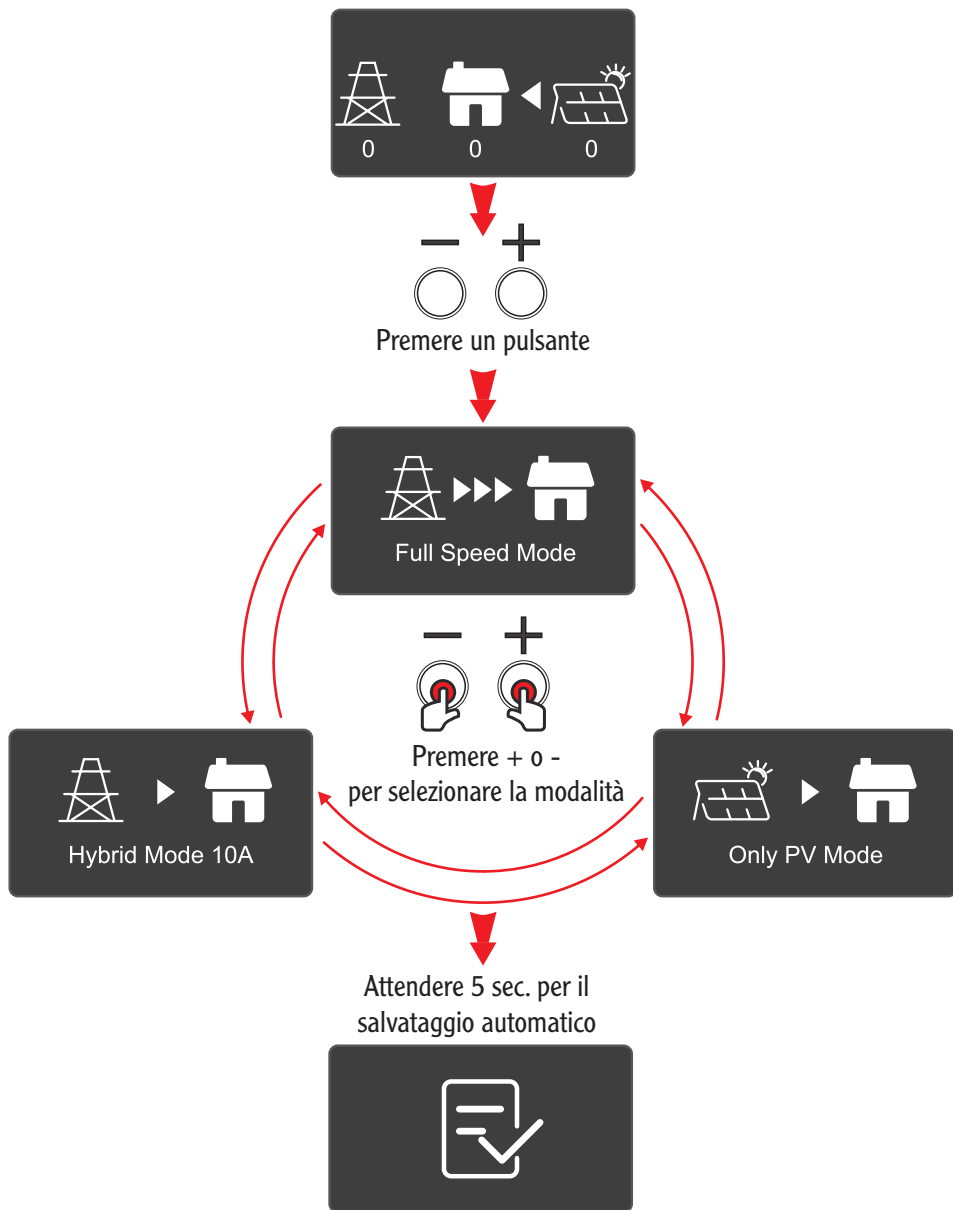

Come scegliere uno degli algoritmi disponibili (solo per versioni DLB-PV)



Risoluzione problemi per DLB-PV

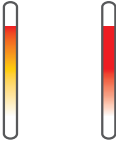

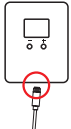
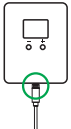
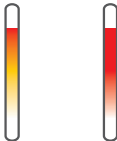
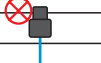
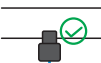
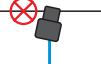
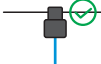
Qualsiasi operazione di controllo e/o riparazione deve essere svolta da personale qualificato. Le riparazioni e verifiche effettuate in autonomia sono ad alto rischio elettrico.

Stato della luce LED sul charger	Tipo di guasto	Possibile causa	Soluzione
 <p data-bbox="227 363 451 448">Sequenza continua di LED giallo e LED rosso, a intermittenza.</p>	DLB offline	 <p data-bbox="684 395 818 448">Cavo ethernet è danneggiato</p>	 <p data-bbox="891 395 1028 448">Sostituire il cavo ethernet</p>
		 <p data-bbox="650 611 852 663">Cavo ethernet non collegato in modo corretto</p>	 <p data-bbox="913 611 1005 639">Ricollegare</p>
 <p data-bbox="247 826 454 938">Un lampeggio del LED giallo seguito da due lampeggi del LED rosso, a ripetizione.</p>	Anomalia nella misura della corrente del DLB	 <p data-bbox="658 762 846 842">Il CT è agganciato sul cavo di alimentazione sbagliato</p>	 <p data-bbox="891 762 1028 842">Verificare che la posizione del CT sia corretta</p>
		 <p data-bbox="650 938 852 1018">Il morsetto del CT è aperto, non collegato in modo corretto</p>	 <p data-bbox="913 962 1005 991">Ricollegare</p>
		 <p data-bbox="661 1185 841 1265">Il collegamento tra il cavo del CT e il DLB è instabile</p>	 <p data-bbox="913 1185 1005 1214">Ricollegare</p>
		<p data-bbox="658 1294 846 1374">Il dispositivo DLB non misura la corrente di carica del charger</p>	<p data-bbox="891 1294 1028 1374">Verificare che la posizione del CT sia corretta</p>

– Le seguenti informazioni riguardano gli stati membri dell’Unione Europea:



INFORMAZIONE AGLI UTENTI Attuazione della direttiva 2012/19/UE.

Il simbolo del cassonetto barrato riportato sull’apparecchiatura o sulla sua confezione indica che il prodotto, alla fine della sua vita utile, deve essere raccolto separatamente dagli altri rifiuti.

La raccolta differenziata della presente apparecchiatura giunta a fine vita è organizzata e gestita dal produttore. L’utente che vorrà disfarsi della presente apparecchiatura dovrà quindi contattare il produttore e seguire il sistema che questo ha adottato per consentire la raccolta separata dell’apparecchiatura giunta a fine vita.

L’adeguata raccolta differenziata per l’avvio successivo dell’apparecchiatura dismessa al riciclaggio, al trattamento ed allo smaltimento ambientalmente compatibile contribuisce ad evitare possibili effetti negativi sull’ambiente e sulla salute e favorisce il reimpiego e/ il riciclo dei materiali di cui è composta l’apparecchiatura.

Lo smaltimento abusivo del prodotto da parte del detentore comporta l’applicazione delle sanzioni amministrative previste.

Condizioni di garanzia

- Il fabbricante garantisce che il prodotto sia privo di difetti di materiale, progettazione e fabbricazione ed idoneo all'uso, previa installazione a regola d'arte, per 2 anni dalla data dell'acquisto.
- La garanzia non copre eventuali danni causati da malfunzionamenti non imputabili al prodotto stesso, eventi naturali, installazione o manutenzione non corretta o effettuata da soggetti non qualificati, utilizzo in contrasto con le istruzioni, normale usura da utilizzo. In ogni caso la garanzia non copre gli eventuali danni economici derivanti dall'impossibilità di utilizzare il prodotto o dalla mancata ricarica del veicolo, nè eventuali danni al veicolo provocati dall'utilizzo di un prodotto non perfettamente funzionante.
- I termini e le condizioni di garanzia dei prodotti CEMBRE sono riportati sul sito **www.cembre.com**, all'interno delle condizioni generali di vendita.
- Il prodotto deve essere installato e riparato esclusivamente da professionisti qualificati, che ne certificano l'esecuzione "a regola d'arte".
- Nel caso in cui si manifestino difetti, guasti o malfunzionamenti durante l'installazione o l'utilizzo del prodotto, ed in ogni caso per l'esercizio della garanzia, si prega di rivolgersi al proprio rivenditore.

Nota: CEMBRE si riserva il diritto di aggiornare i contenuti del presente documento senza preavviso e in qualsiasi momento. Si prega di verificare la presenza di eventuali aggiornamenti utilizzando il QR code presente nel packaging.

1. INFORMATIONS GÉNÉRALES

Module DLB Standard

Les chargeurs de la série BIAN.CO peuvent être équipés d'un dispositif DLB (Dynamic Load Balancing) pour l'équilibrage dynamique de la charge électrique. Il se compose d'un module qui peut être installé sur un rail DIN ou un support plat, et d'un ou plusieurs transformateurs de courant ouvrables (ou « TC »), à fixer sur les conducteurs de phase : lorsque d'autres charges sont présentes sur la ligne du chargeur, le DLB est en mesure de limiter automatiquement l'appel de courant total du chargeur, de manière à ce que le système de recharge ne soit pas la cause principale d'une surcharge sur la ligne d'alimentation.

DLB1 (monophasé)

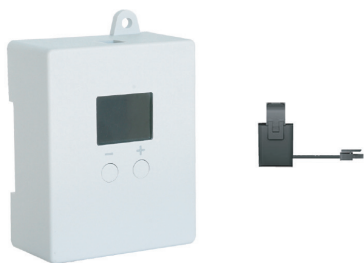

DLB3 (triphasé)



Module DLB-PV (pour photovoltaïque)

Le DLB-PV permet d'intégrer également une installation photovoltaïque dans le système : en plus des fonctionnalités du DLB de type Standard, le DLB-PV est capable d'exploiter l'apport de l'installation photovoltaïque, en optimisant et/ou en maximisant la distribution de différentes manières :

- **Full Speed Mode** (Mode pleine vitesse) utilise à la fois l'énergie du réseau et l'énergie photovoltaïque
- **Only PV Mode** (Mode photovoltaïque seul) utilise uniquement l'énergie produite par l'installation photovoltaïque
- **Mode hybride** (maximise la distribution d'énergie issue du photovoltaïque, avec une quantité maximale configurable d'énergie issue du réseau)



DLB1-PV (monophasé)

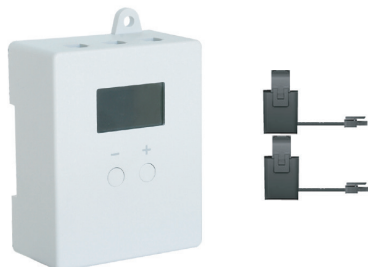

DLB3-PV (triphasé)

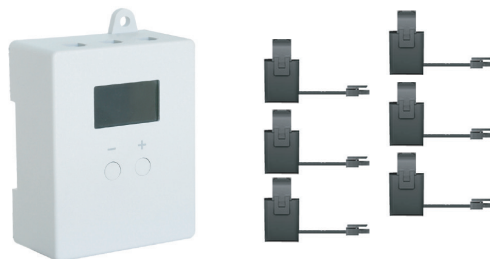

i Le DLB-PV peut également être utilisé comme DLB standard sans intégration photovoltaïque.

Dans l'emballage :

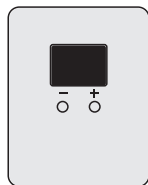

Dispositif DLB
X1

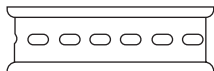

Rail Din 105 mm

X1

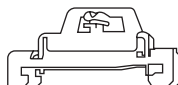

Pièces de montage pour rail Din

X2



Vis à expansion
M4x30

X2



Transformateur de courant (TC)

X1 (DLB monophasé)

X3 (DLB3 triphasé)

X2 (DLB-PV monophasé)

X6 (DLB3-PV triphasé)



Câble réseau - 5 m

(câble RJ45 TIA/EIA-568B cat5 à 8 conducteurs)

X1

2. DLB STANDARD : SPÉCIFICATIONS ET INSTALLATION

Spécifications DLB standard

Type	DLB1	DLB3
Installation	monophasé	triphase
Dimensions / Poids	82x67x35 mm / 100 g	82x67x35 mm / 100 g
Mode « Extreme »	√	√
standard à photovoltaïque / Photovoltaïque à standard	-	-
Mode Night Automatic Full Speed (Nuit automatique pleine vitesse)	-	-
Transformateurs de courant fournis	1	3
Affichage	LED, à segments	OLED, graphique
Connexion entre le DLB et le chargeur	dans les 300 m (câble réseau standard de 5 m)	
Longueur standard du câble TC	1,5 m (personnalisable jusqu'à 15 m)	
Installation	Installation sur rail DIN / fixation par vis	
Communication	RS485 (via un câble Ethernet)	

i Aucune alimentation supplémentaire n'est nécessaire : le boîtier DLB Standard est alimenté par le chargeur via Ethernet.

- **Qu'est-ce que le mode « Extreme »** : dans ce mode, si le courant requis par les charges domestiques continue à augmenter, la recharge est suspendue pour éviter toute surcharge. La recharge reprend lorsqu'un courant d'au moins 10 A est à nouveau disponible. Le mode DLB Extreme peut être activé via l'application BIAN.CO Easy (pour les modalités d'activation, se référer au manuel dédié).

Comment fonctionne le dispositif DLB

Pour le dispositif DLB monophasé (DLB1) :

Courant du chargeur = courant maxi. du réseau (réglé sur le DLB) - courant de charges domestiques

Pour le dispositif DLB triphasé (DLB3) :

Courant du chargeur = le plus faible entre :

courant maximal du réseau phase L1 (réglé sur le DLB) - courant de charge domestique phase L1

courant maximal du réseau phase L2 (réglé sur le DLB) - courant de charge domestique phase L2

courant maximal du réseau phase L3 (réglé sur le DLB) - courant de charge domestique phase L3

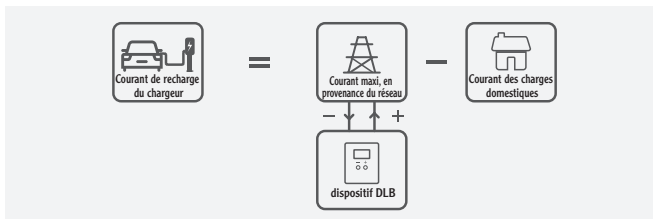

Stations de recharge multiples

Supposons que le chargeur ② soit déjà en train de charger un véhicule ① au moment de commencer une session de recharge :

- Courant maximal du chargeur ① = Courant maximal du réseau (réglé sur le DLB) - Courant de charges domestiques

- Courant maximal du chargeur ② = Courant maximal du réseau (réglé sur le DLB) - Courant de charges domestiques - Chargeur ①.

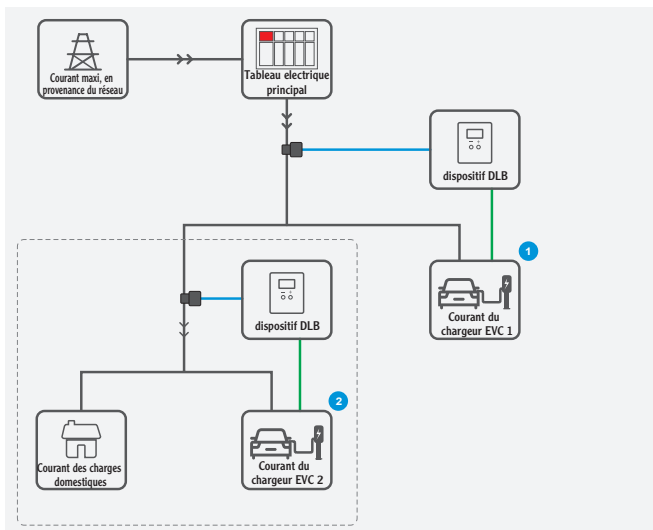

Comment installer le dispositif DLB



L'installation des TC nécessite un contact avec des conducteurs potentiellement sous tension: le travail d'installation doit donc être effectué par un personnel qualifié et professionnel.



Un mauvais positionnement des TC entraîne un mauvais fonctionnement du DLB: suivre scrupuleusement les instructions données dans ce manuel.



Dans la version triphasée DLB3, la séquence des phases doit être respectée et doit être la même que celle utilisée pour le chargeur. Les inversions de phase peuvent générer des dysfonctionnements dans le dispositif DLB.

ÉTAPE 1 - Installation du transformateur de courant (TC)

- Ouvrir et connecter la borne TC immédiatement en aval de l'interrupteur général du tableau de distribution. Le schéma suivant illustre la position et les connexions entre les différents composants du système:

CAS 1 - Charges domestiques et lignes de chargeur de véhicule électrique en parallèle

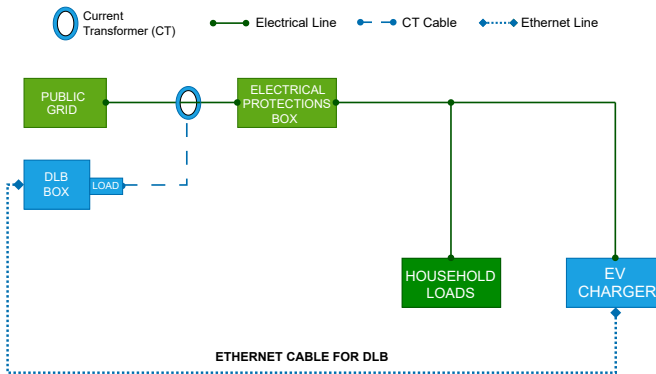

CAS 2 - Charges domestiques et lignes de chargeur de véhicule électrique en série

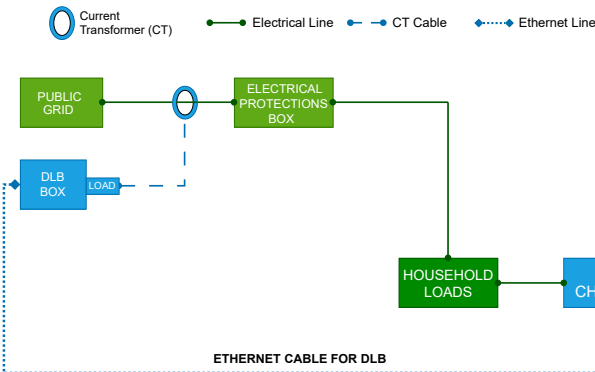

cas 3 - Installation système photovoltaïque avec un DLB standard (non DLB-PV)

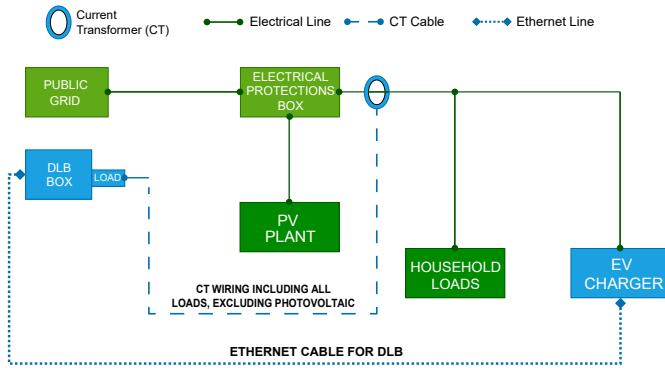

! Ces schémas de câblage s'appliquent uniquement à DLB1 et DLB3 ; veuillez vous référer aux pages suivantes pour DLB1-PV et DLB3-PV.

- Dans le cas d'un DLB monophasé, connecter le TC sur le conducteur de phase du réseau (voir figure).
- Dans le cas d'un DLB3 triphasé, connecter les trois TC, un sur chaque phase (voir figure).
- Connecter correctement les câbles des TC au dispositif DLB: la présence de connecteurs à l'extrémité du câble de chaque TC facilite et stabilise la connexion au DLB.

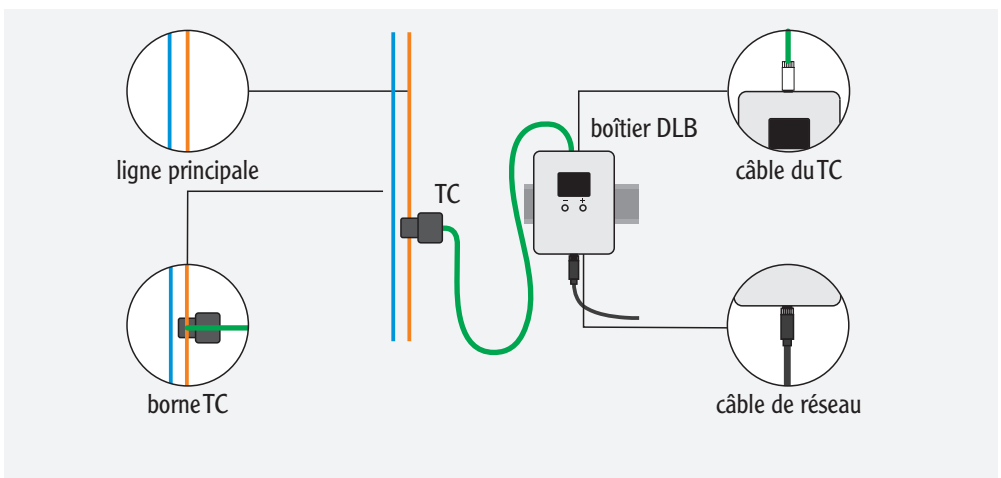
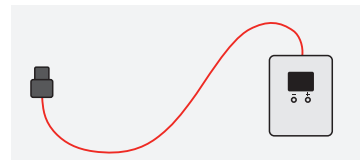
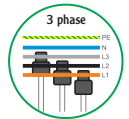
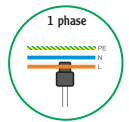

ÉTAPE 2 - Connexion au chargeur via le câble de réseau

Connecter le dispositif DLB au chargeur via le câble de réseau : ce câble transporte à la fois l'énergie et les données de communication entre le chargeur et le dispositif DLB.

Procédure :

1. Couper l'alimentation électrique du chargeur.
2. Retirer le panneau avant du chargeur.
3. Insérer le câble Ethernet dans le chargeur, les modes d'entrée possibles du câble sont indiqués dans le manuel d'installation du chargeur.
4. Identifier le port Ethernet sur la carte électronique (voir figure) et y connecter le câble Ethernet.
5. Repositionner le panneau avant du chargeur et réactiver l'alimentation électrique.
6. Connecter l'autre extrémité du câble Ethernet sur la partie inférieure du DLB. Si le boîtier DLB démarre, vous pouvez passer aux étapes suivantes.
7. Redémarrer le chargeur : il suffit de couper l'alimentation pendant 5 secondes et de la réactiver.

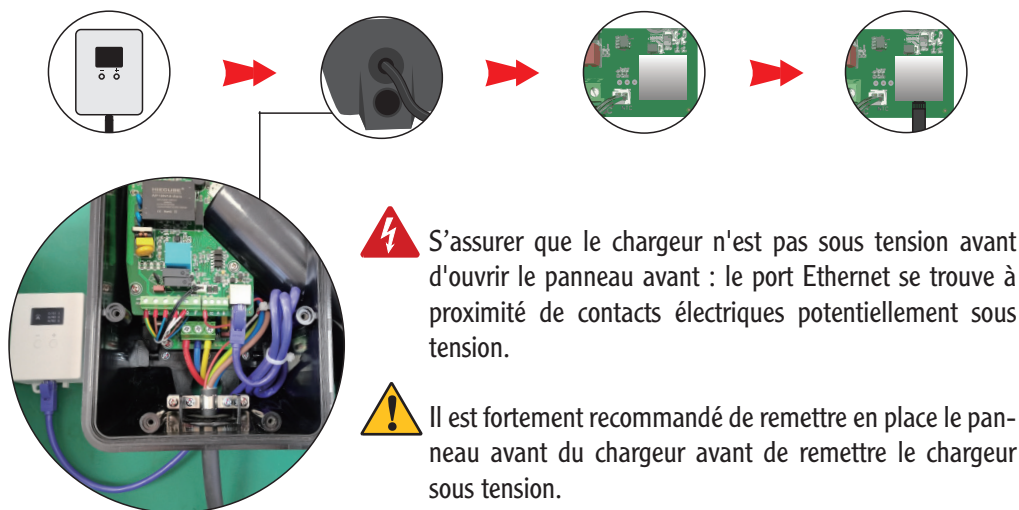

S'assurer que le chargeur n'est pas sous tension avant d'ouvrir le panneau avant : le port Ethernet se trouve à proximité de contacts électriques potentiellement sous tension.



Il est fortement recommandé de remettre en place le panneau avant du chargeur avant de remettre le chargeur sous tension.



Si le dispositif DLB ne s'allume pas, vérifier que le câble Ethernet est correct et que la connexion est stable.

Câble de réseau recommandé

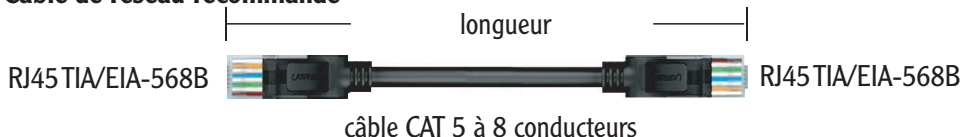

Comment régler le courant maximal du réseau sur le dispositif DLB standard

- Dispositif DLB1 monophasé

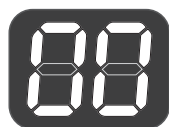

Courant mesuré

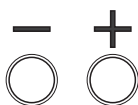

Appuyer sur
n'importe quel
bouton



Valeur de consigne

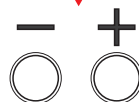

Appuyer sur '+' ou
'-' pour ajuster la
valeur

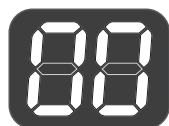

Courant mesuré



Attendre 5 s jusqu'à
l'enregistrement
automatique



Valeur de consigne





Pour fonctionner correctement, le courant maximal de fonctionnement doit être réglé à une valeur inférieure ou égale au courant de réseau disponible d'après le contrat avec le distributeur.



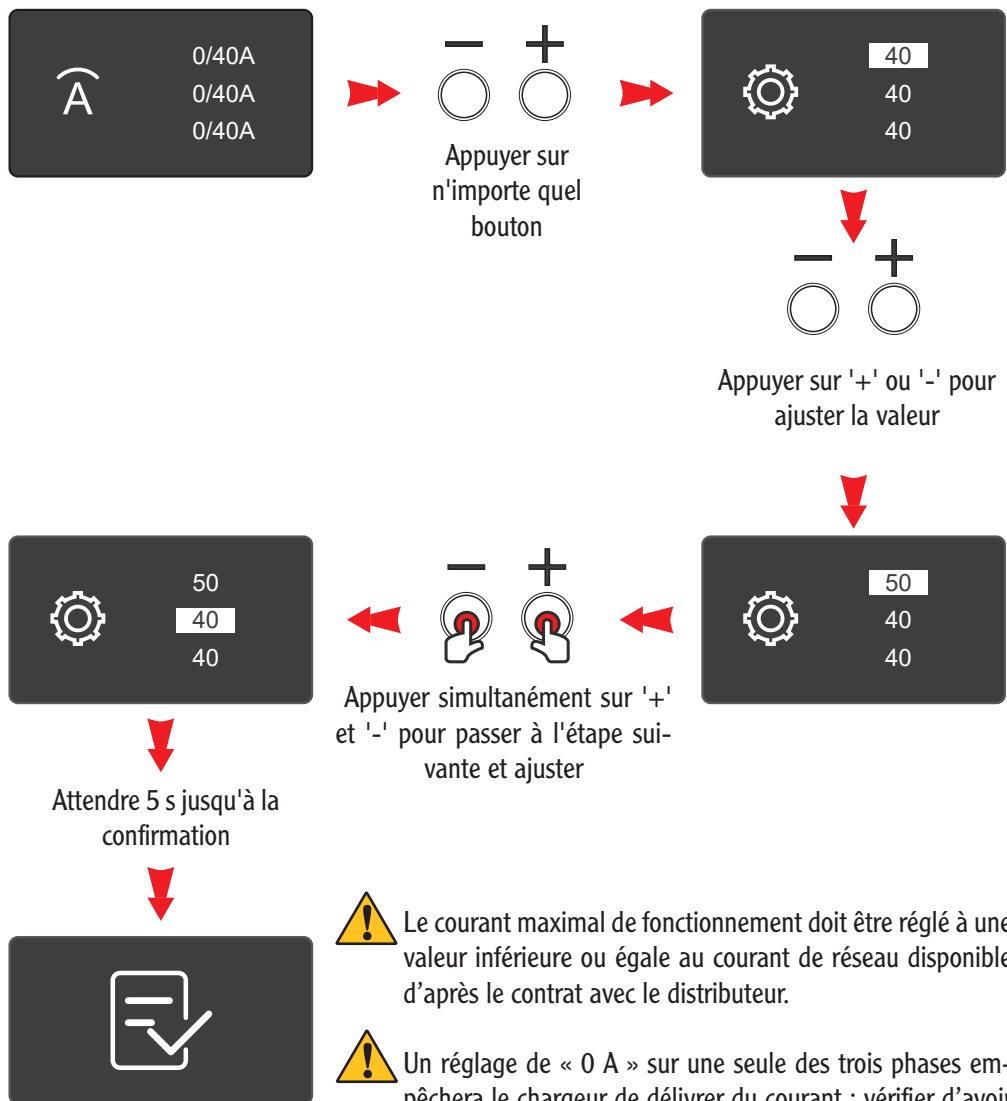

En cas de modifications contractuelles avec le distributeur impliquant un changement de puissance (et donc de courant) maximale, il faudra impérativement mettre à jour également le réglage du courant maximal du DLB.

- Dispositif DLB3 triphasé



 Le courant maximal de fonctionnement doit être réglé à une valeur inférieure ou égale au courant de réseau disponible d'après le contrat avec le distributeur.

 Un réglage de « 0 A » sur une seule des trois phases empêchera le chargeur de délivrer du courant : vérifier d'avoir toujours défini les bons paramètres pour chaque phase.







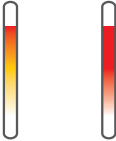

 En cas de modifications contractuelles avec le distributeur impliquant un changement de puissance (et donc de courant) maximale, il faudra impérativement mettre à jour également le réglage du courant maximal du DLB.

Dépannage pour le DLB standard

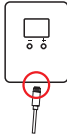
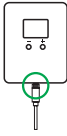
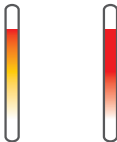

Toute inspection et/ou réparation doit être effectuée par un personnel qualifié.

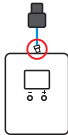
Les réparations et les contrôles effectués par l'utilisateur lui-même présentent un risque électrique élevé.

État de la lumière LED sur le chargeur	Type de défaut	Cause possible	Solution
 <p>Séquence continue des LED jaune et rouge par intermittence</p>	DLB hors ligne	 <p>Câble Ethernet endommagé</p>	 <p>Remplacer le câble Ethernet</p>
		 <p>Câble Ethernet mal connecté</p>	 <p>Reconnecter</p>
 <p>Un clignotement de la LED jaune suivi de deux clignotements de la LED rouge, de façon répétée</p>	Anomalie dans la mesure du courant du DLB	 <p>Le TC est branché sur le mauvais câble d'alimentation</p>	 <p>Vérifier que la position du TC est correcte</p>
		 <p>La borne du TC est ouverte et n'est pas connectée de manière stable</p>	 <p>Reconnecter</p>
		 <p>La connexion entre le câble du TC et le DLB est instable</p>	 <p>Reconnecter</p>
		<p>Le dispositif DLB ne mesure pas le courant de charge du chargeur</p>	<p>Vérifier que la position du TC est correcte</p>

3. DLB-PV : SPÉCIFICATIONS ET INSTALLATION

Caractéristiques des DLB-PV pour installations photovoltaïques



Type	DLB1-PV	DLB3-PV
Installation	monophasé	triphase
Dimensions / Poids	82x67x35 mm / 100 g	82x67x35 mm / 100 g
Mode « PV Extreme »	✓	✓
Possibilité de fonctionnement sans photovoltaïque	✓	✓
Mode Night Automatic Full Speed (Nuit automatique pleine vitesse)	✓	✓
Transformateurs de courant TC fournis	2	6
Affichage	OLED, graphique	OLED, graphique
Connexion entre le DLB et le chargeur	dans les 300 m (câble réseau standard de 5 m)	
Longueur du câble du TC	1,5 m (personnalisable jusqu'à 15 m)	
Installation	Installation sur rail DIN / fixation par vis	
Communication	RS485 (via un câble Ethernet)	

i Aucune alimentation supplémentaire n'est nécessaire : DLB est alimenté par le chargeur via Ethernet

- **Qu'est-ce que le mode « Extreme »** : dans ce mode, si le courant requis par les charges domestiques continue d'augmenter et que l'énergie fournie par l'installation photovoltaïque n'est pas suffisante pour maintenir le courant minimal du chargeur, la recharge est interrompue pour éviter toute surcharge. La recharge redémarre automatiquement lorsque le courant disponible sur la ligne est supérieur ou égal à 10A. Ce mode peut être activé via l'application BIAN.CO Easy (voir le manuel pour plus de détails).
- **Qu'est-ce que le mode « Night Automatic Full Speed »** : dans ce mode, le chargeur continue de recharger le véhicule électrique à la vitesse maximale possible de 20h00 à 06h00. Ce mode peut être configuré et activé via l'application BIAN.CO Easy (voir le manuel pour plus de détails).

Comment fonctionne le dispositif DLB-PV pour photovoltaïque

DLB1-PV pour le système monophasé :

Courant du chargeur = Courant maximal du réseau + Courant photovoltaïque - Courant des charges domestiques

DLB3-PV pour le système triphasé :

Courant du chargeur = Courant maximal du réseau + (courant photovoltaïque - courant des charges domestiques) / 3

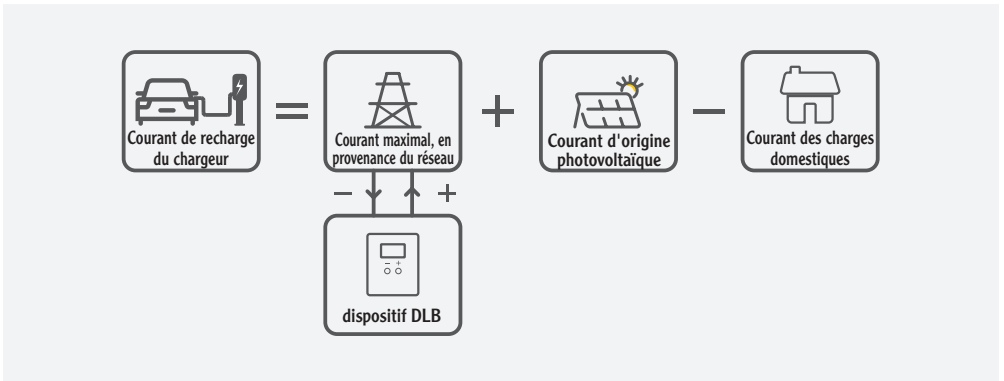

Comment installer le dispositif DLB-PV pour photovoltaïque

Ouvrir et connecter la ou les pinces CT du ou des transformateurs de courant, selon l'un des cas suivants.

cas 1 - Charges domestiques et lignes de chargeur de véhicule électrique en parallèle

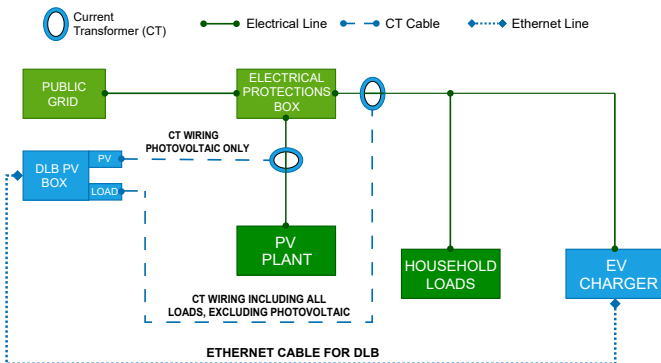

cas 2 - Charges domestiques et lignes de chargeur de véhicule électrique en série

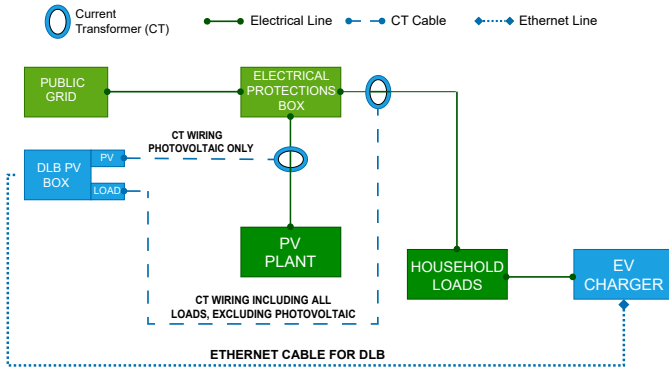

Comme pour le DLB Standard, l'installation des TC nécessite un personnel qualifié car ils sont potentiellement en contact avec des pièces sous tension.



Afin de travailler en toute sécurité, il est recommandé de couper l'alimentation de l'onduleur de l'installation photovoltaïque avant de positionner les TC correspondants.

Quels sont les algorithmes applicables au DLB-PV

Algorithme de recharge	fonctionnement
<p>Only PV</p> <p>Only PV Mode</p>	<p>En mode « Only PV », le chargeur module automatiquement le courant de recharge maximal afin de ne pas demander de courant supplémentaire au réseau public</p>
<p>Hybrid</p> <p>Hybrid Mode 10A</p>	<p>En mode « Hybrid », le chargeur module automatiquement le courant de recharge maximal afin de ne jamais tirer plus de courant du secteur que la quantité paramétrée</p>
<p>Full Speed</p> <p>Full Speed Mode</p>	<p>En mode « Full Speed », le chargeur module automatiquement le courant de recharge maximal afin de maximiser la puissance délivrée, en fonction de la puissance totale disponible</p>

Comment passer du mode PV au mode Standard (uniquement pour DLB-PV)

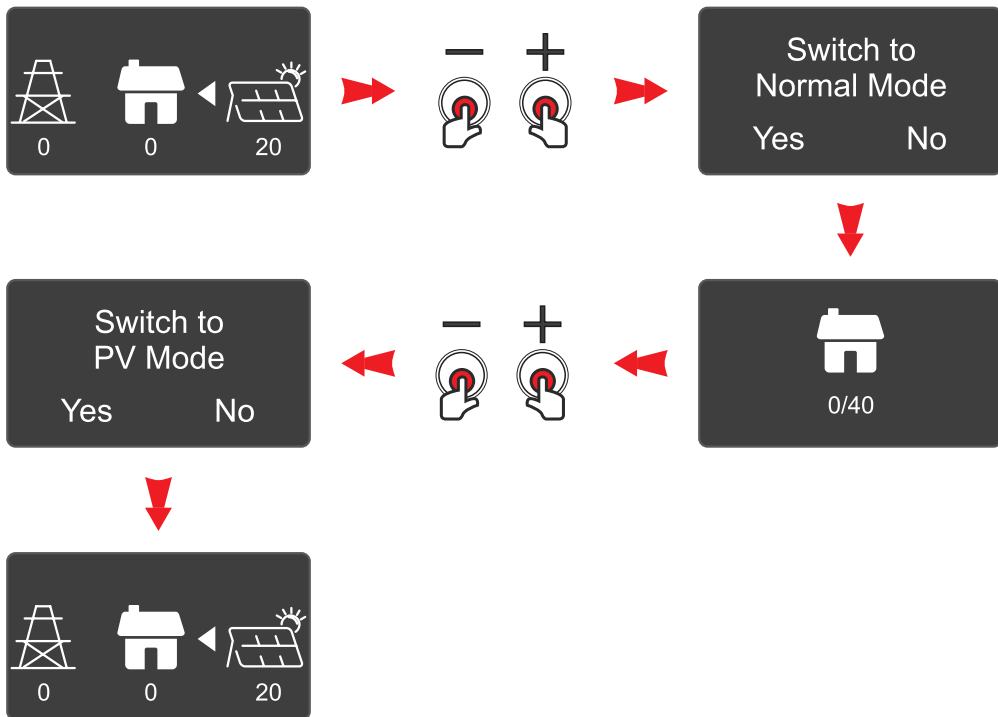



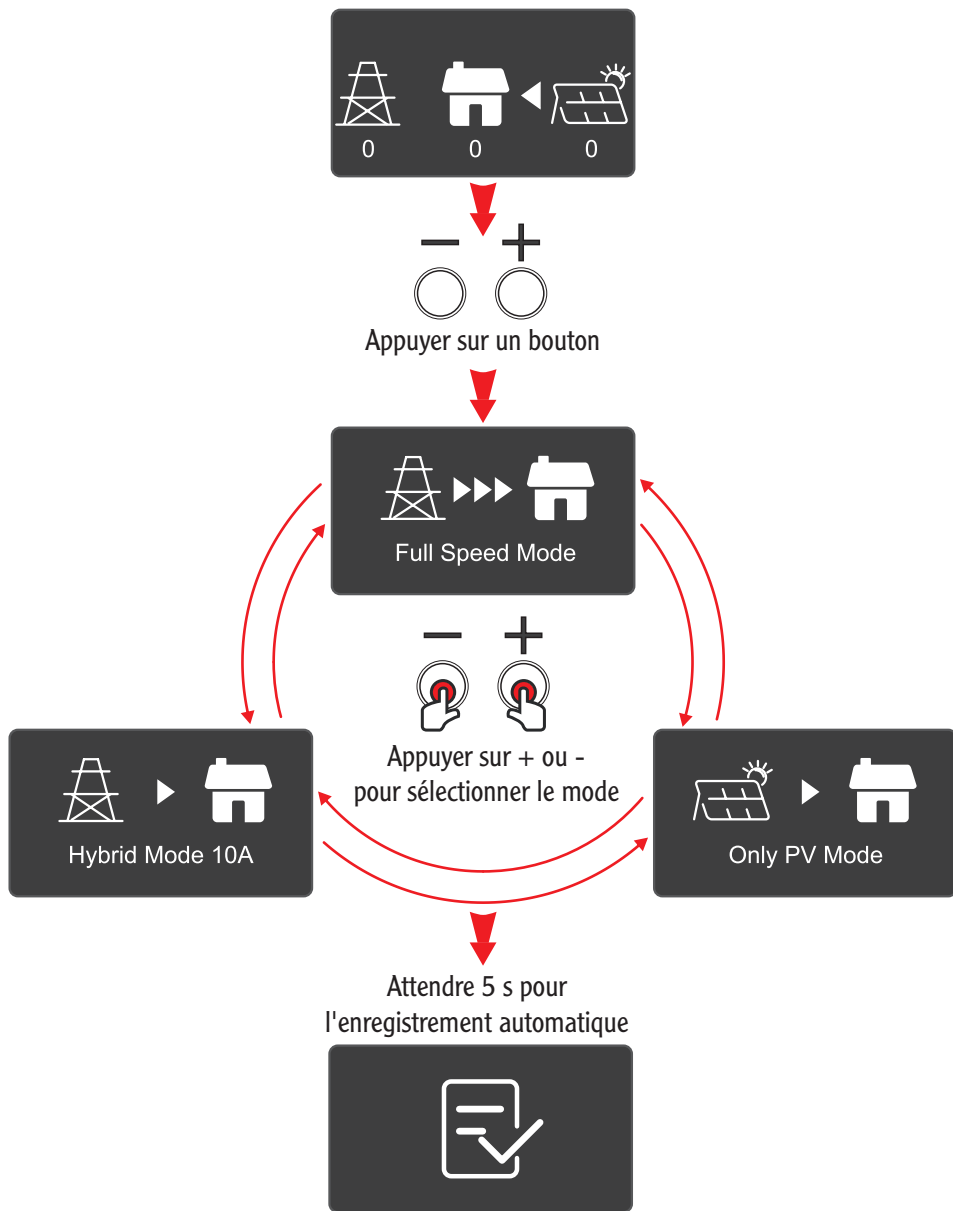

Comment choisir l'un des algorithmes disponibles (uniquement pour DLB-PV)



Dépannage pour DLB-PV

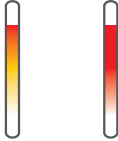

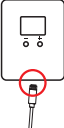
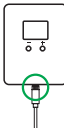
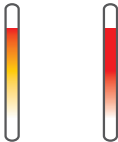
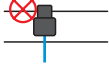
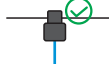
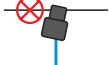
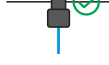
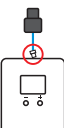
Toute inspection et/ou réparation doit être effectuée par un personnel qualifié.
Les réparations et les contrôles effectués par l'utilisateur lui-même présentent un risque électrique élevé.

État de la lumière LED sur le chargeur	Type de défaut	Cause possible	Solution
 <p>Séquence continue des LED jaune et rouge par intermittence.</p>	DLB hors ligne	 <p>Le câble Ethernet est endommagé</p>	 <p>Remplacer le câble Ethernet</p>
		 <p>Câble Ethernet mal connecté</p>	 <p>Reconnecter</p>
 <p>Un clignotement de la LED jaune suivi de deux clignotements de la LED rouge, de manière répétée.</p>	Anomalie dans la mesure du courant du DLB	 <p>Le TC est branché sur le mauvais câble d'alimentation</p>	 <p>Vérifier que la position du TC est correcte</p>
		 <p>La borne du TC est ouverte, mal connectée</p>	 <p>Reconnecter</p>
		 <p>La connexion entre le câble du TC et le DLB est instable</p>	 <p>Reconnecter</p>
		<p>Le dispositif DLB ne mesure pas le courant de charge du chargeur</p>	<p>Vérifier que la position du TC est correcte</p>

- Les informations suivantes concernent les États membres de l'Union européenne :



INFORMATION AUX UTILISATEURS Mise en œuvre de la directive 2012/19/UE.

Le symbole de la poubelle barrée sur l'équipement ou son emballage indique que le produit, en fin de vie, doit être collecté séparément des autres déchets.

La collecte séparée du présent équipement une fois arrivé en fin de vie est organisée et gérée par le fabricant. L'utilisateur qui souhaiterait se débarrasser de cet équipement devra donc contacter le fabricant et suivre le système que ce dernier a adopté pour permettre la collecte séparée de l'équipement en fin de vie.

Une collecte séparée adéquate en vue d'un recyclage, d'un traitement et d'une élimination éco-responsable de l'équipement mis au rebut permet d'éviter d'éventuels effets négatifs sur l'environnement et sur la santé et favorise la réutilisation et/ou le recyclage des matériaux qui composent l'équipement.

L'élimination abusive du produit par son détenteur entraînera l'application des sanctions administratives prévues.

Conditions de garantie

- Le fabricant garantit que le produit est exempt de tout défaut de matériau, de conception et de fabrication et qu'il convient à l'utilisation, après une installation correcte, pendant 2 ans à compter de la date d'achat.
- La garantie ne couvre pas les éventuels dommages causés par des dysfonctionnements non imputables au produit lui-même, des événements naturels, une installation ou un entretien incorrects ou effectués par des personnes non qualifiées, une utilisation contraire aux instructions, l'usure normale due à l'utilisation. En tout état de cause, la garantie ne couvre pas les éventuels dommages économiques résultant de l'impossibilité d'utiliser le produit ou de charger le véhicule, ni les éventuels dommages causés au véhicule par l'utilisation d'un produit qui ne fonctionne pas parfaitement.
- Les conditions générales de garantie des produits CEMBRE se trouvent sur le site web **www.cembre.com**, dans les conditions générales de vente.
- Le produit ne doit être installé et réparé que par des professionnels qualifiés, qui en certifient l'exécution « dans les règles de l'art ».
- En cas de défauts, de défaillances ou de dysfonctionnements survenant lors de l'installation ou de l'utilisation du produit, et en tout état de cause pour l'exercice de la garantie, veuillez contacter votre revendeur.

Note : CEMBRE se réserve le droit de mettre à jour le contenu de ce document sans préavis et à tout moment. Veuillez vérifier les éventuelles mises à jour en utilisant le code QR présent sur l'emballage.

1. INFORMACIÓN GENERAL

Módulo DLB estándar

Los cargadores de la serie BIAN.CO pueden equiparse con un dispositivo DLB (Dynamic Load Balancing) para el equilibrio dinámico de la carga eléctrica. Consta de un módulo que puede instalarse en un carril DIN o en un soporte plano, y de uno o varios transformadores de corriente (o “TC”) que pueden abrirse y que se conectan a los conductores de fase: cuando hay otras cargas presentes en la línea del cargador, el DLB es capaz de limitar automáticamente el consumo total de corriente del cargador, para que el sistema de carga no sea la causa principal de una sobrecarga en la línea eléctrica.

DLB1 (monofásico)

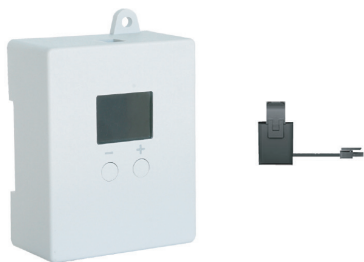

DLB3 (trifásico)

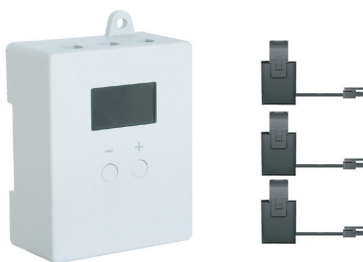

Módulo DLB-PV (para sistemas fotovoltaicos)

El DLB-PV también permite integrar un sistema fotovoltaico en el sistema: además de la funcionalidad del DLB Estándar, el DLB-PV es capaz de aprovechar la contribución del sistema fotovoltaico, optimizando y/o maximizando el suministro de diferentes maneras:

- **Full Speed Mode** utiliza tanto la red eléctrica como la energía fotovoltaica
- **Only PV Mode** utiliza únicamente la energía producida por el sistema fotovoltaico
- **Modo híbrido** (maximiza la producción utilizando energía fotovoltaica y una cantidad máxima configurable de energía de la red)



DLB1-PV (monofásico)

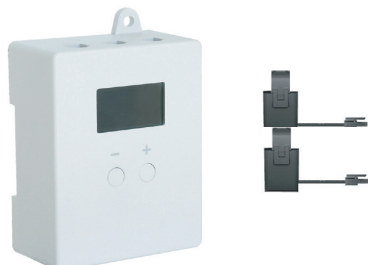

DLB3-PV (trifásico)

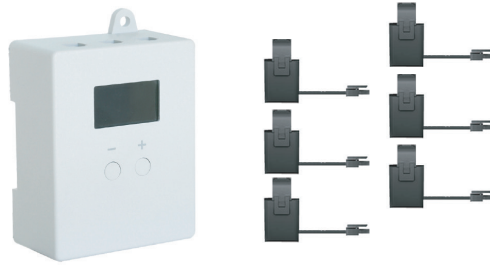

El DLB-PV también puede utilizarse como DLB estándar sin integración fotovoltaica.

En la caja:

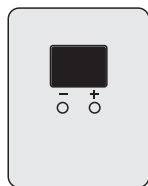

Dispositivo DLB
X1

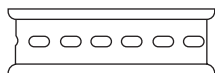

Carril Din 105 mm

X1

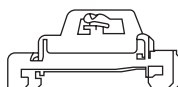

Piezas de montaje para carril DIN

X2



Tornillo de expansión
M4x30

X2



Transformador de corriente (TC)

X1 (DLB monofásico)

X3 (DLB3 trifásico)

X2 (DLB-PV monofásico)

X6 (DLB3-PV trifásico)





Cable de red - 5 m

(cable RJ45 TIA/EIA-568B cat5 de 8 núcleos)

X1

2. ESTÁNDAR DLB: ESPECIFICACIONES E INSTALACIÓN

Especificaciones estándar DLB

		
Tipo	DLB1	DLB3
Instalación	monofásico	trifásico
Dimensiones / Peso	82x67x35 mm / 100 g	82x67x35 mm / 100 g
Modo “Extremo”	√	√
De estándar a fotovoltaico / De fotovoltaico a estándar	-	-
Modo Night Automatic Full Speed	-	-
Transformadores de corriente en dotación	1	3
Pantalla	LED, segmentado	OLED, gráfico
Conexión entre el DLB y el cargador	máx. 300 m (cable de red estándar de 5 m)	
Longitud estándar del cable del TC	1,5 m (personalizable hasta 15 m)	
Instalación	Instalación en carril DIN / fijación con tornillos	
Comunicación	RS485 (mediante cable Ethernet)	

i No se necesita ninguna fuente de alimentación adicional: la caja DLB Standard se alimenta del cargador a través de Ethernet.

- **Qué es el modo “Extremo”:** en este modo, si la corriente requerida por las cargas domésticas sigue aumentando, la carga se suspende para evitar sobrecargas.

La carga se reanuda cuando vuelve a estar disponible una corriente de al menos 10 A.

El modo DLB Extreme se puede activar a través de la aplicación BIAN.CO Easy (para conocer los métodos de activación, consulta el manual específico).

Funcionamiento del dispositivo DLB

Para dispositivo DLB monofásico (DLB1):

Corriente del cargador = corriente de red máxima (configurada en DLB) - Corriente de carga doméstica

Para el dispositivo DLB trifásico (DLB3):

Corriente del cargador = la menor de:

corriente de red máxima fase L1 (configurada en DLB) - corriente de carga doméstica fase L1

corriente de red máxima fase L2 (configurada en DLB) - corriente de carga doméstica fase L2

corriente de red máxima fase L3 (configurada en DLB) - corriente de carga doméstica fase L3

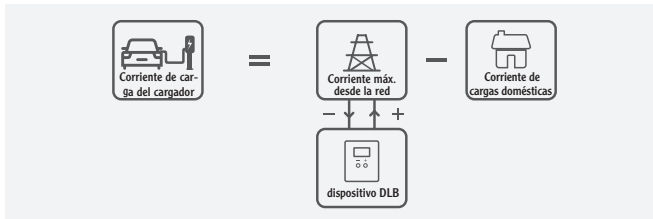

Estaciones de carga múltiple

Suponiendo la condición de que, en el momento en que el Cargador 2 inicia una sesión de carga, el Cargador 1 ya está cargando un vehículo:

- Corriente máxima del cargador 1 = Corriente máxima de la red (configurada en DLB) - Corriente de carga doméstica.
- Corriente máxima del cargador 2 = Corriente máxima de la red (configurada en DLB) - Corriente de carga doméstica - Cargador 1.

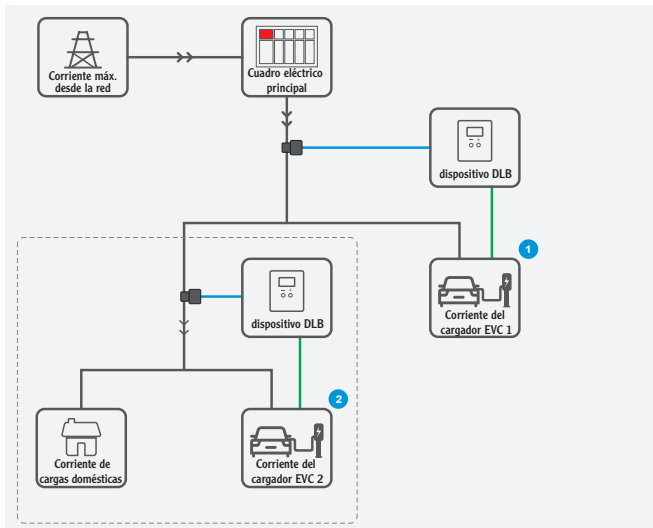

Cómo instalar el dispositivo DLB



La instalación de TC requiere el contacto con conductores potencialmente bajo tensión: por lo tanto, la actividad de instalación la debe realizar personal cualificado y profesional.



La colocación incorrecta de los TC provoca el mal funcionamiento del DLB: seguir escrupulosamente las instrucciones de este manual.



En la versión trifásica DLB3, se debe respetar la secuencia de fases, que debe ser la misma que la utilizada para el cargador. Las inversiones de fase pueden generar disfunciones en el sistema DLB.

PASO 1 - Instalación del transformador de corriente (TC)

- Abra y conecte la(s) pinza(s) CT del(los) transformador(es) de corriente, de acuerdo con uno de los siguientes casos.

CASO 1 - Líneas de carga doméstica y cargadores EV en paralelo

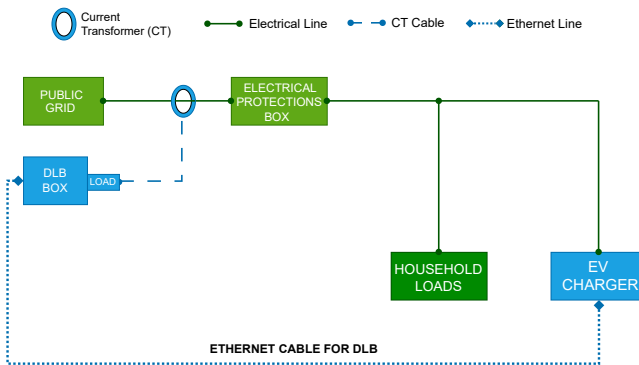

CASO 2 - Líneas de carga doméstica y cargadores EV en serie

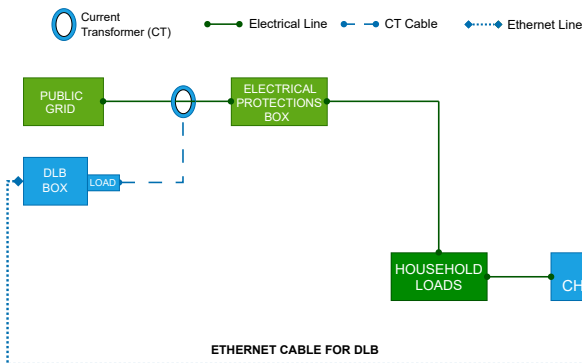

CASO 3 - Planta fotovoltaica con una dispositivo DLB no fotovoltaica

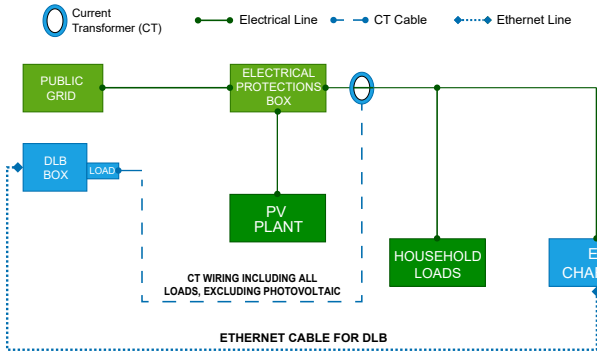

Estos esquemas de cableado son aplicables únicamente a DLB1 y DLB3; consulte las páginas siguientes para DLB1-PV y DLB3-PV.

- En el caso de DLB monofásico, conectar el TC al conductor de fase de la red. (ver figura).
- En el caso del DLB3 trifásico, conectar los tres TC, uno en cada fase (véase la figura).
- Conectar correctamente los cables del TC al dispositivo DLB: la presencia de conectores en la cabeza del cable de cada TC facilita y estabiliza la conexión al DLB.

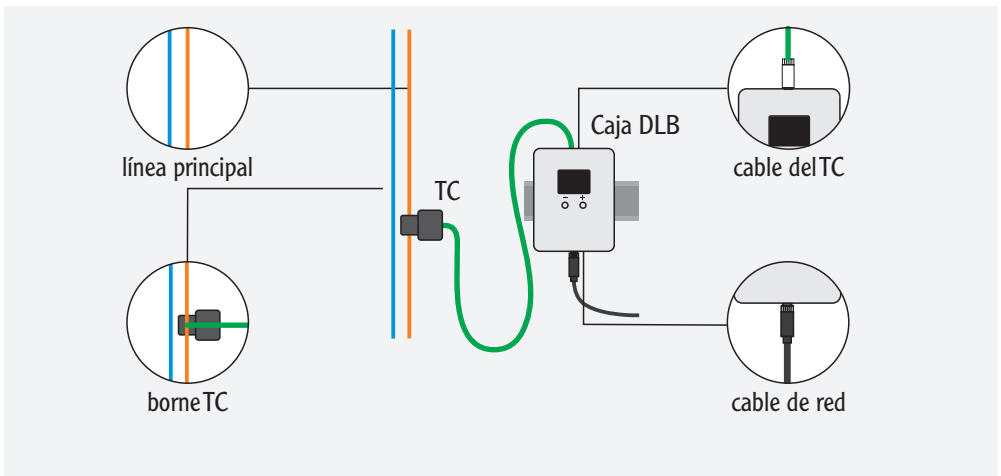
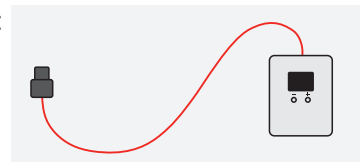
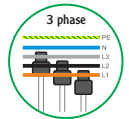
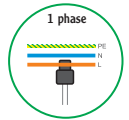

PASO 2 - Conexión al cargador mediante cable de red

Conectar el dispositivo DLB al cargador mediante el cable de red: este cable transporta tanto la energía como los datos de comunicación entre el cargador y el dispositivo DLB.

Procedimiento:

1. Interrumpir la alimentación del cargador.
2. Retirar el panel frontal del cargador.
3. Conectar el cable Ethernet al cargador; los posibles modos de entrada del cable se indican en el manual de instalación del cargador.
4. Identificar el puerto Ethernet en la tarjeta electrónica (véase la figura) y conectar el cable Ethernet.
5. Volver a colocar el panel frontal del cargador y reactivar la línea de alimentación.
6. Conectar el otro extremo del cable Ethernet a la parte inferior del DLB. Si la caja DLB se inicia, se puede continuar con los pasos siguientes.
7. Reinicio del cargador: basta con desconectar la alimentación durante 5 segundos y volver a encenderlo.

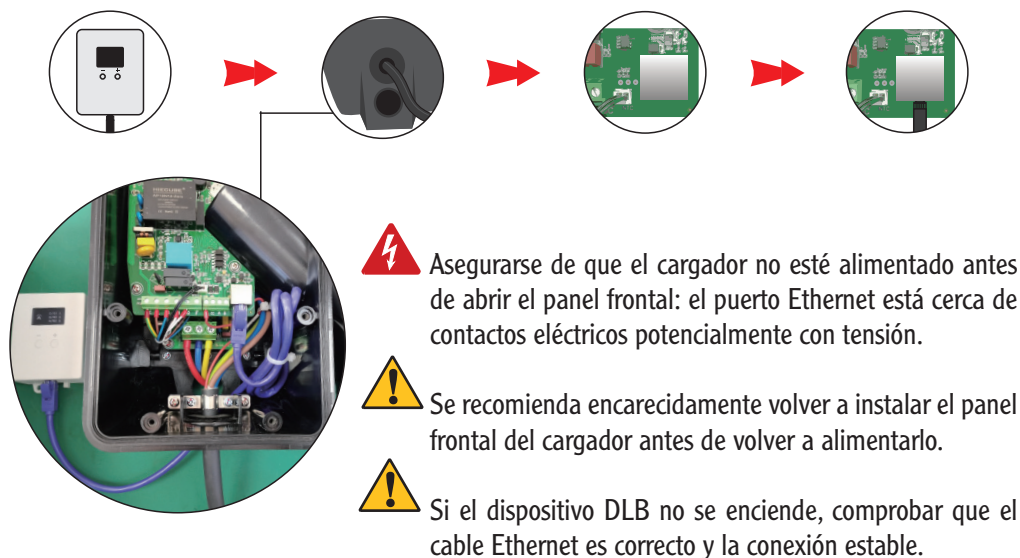

Cable de red recomendado



Cómo configurar la corriente de red máxima en el dispositivo DLB estándar

- Dispositivo monofásico DLB1



Corriente medida



Pulsar cualquier botón



Valor configurado

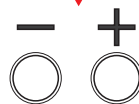

Pulsar "+" o "-" para regular el valor



Valor configurado



Esperar 5 s hasta que se guarde automáticamente

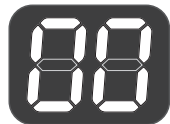

Corriente medida





Para que funcione correctamente, la corriente máxima de funcionamiento debe configurarse a un valor inferior o igual a la corriente de red disponible según contrato con el distribuidor.



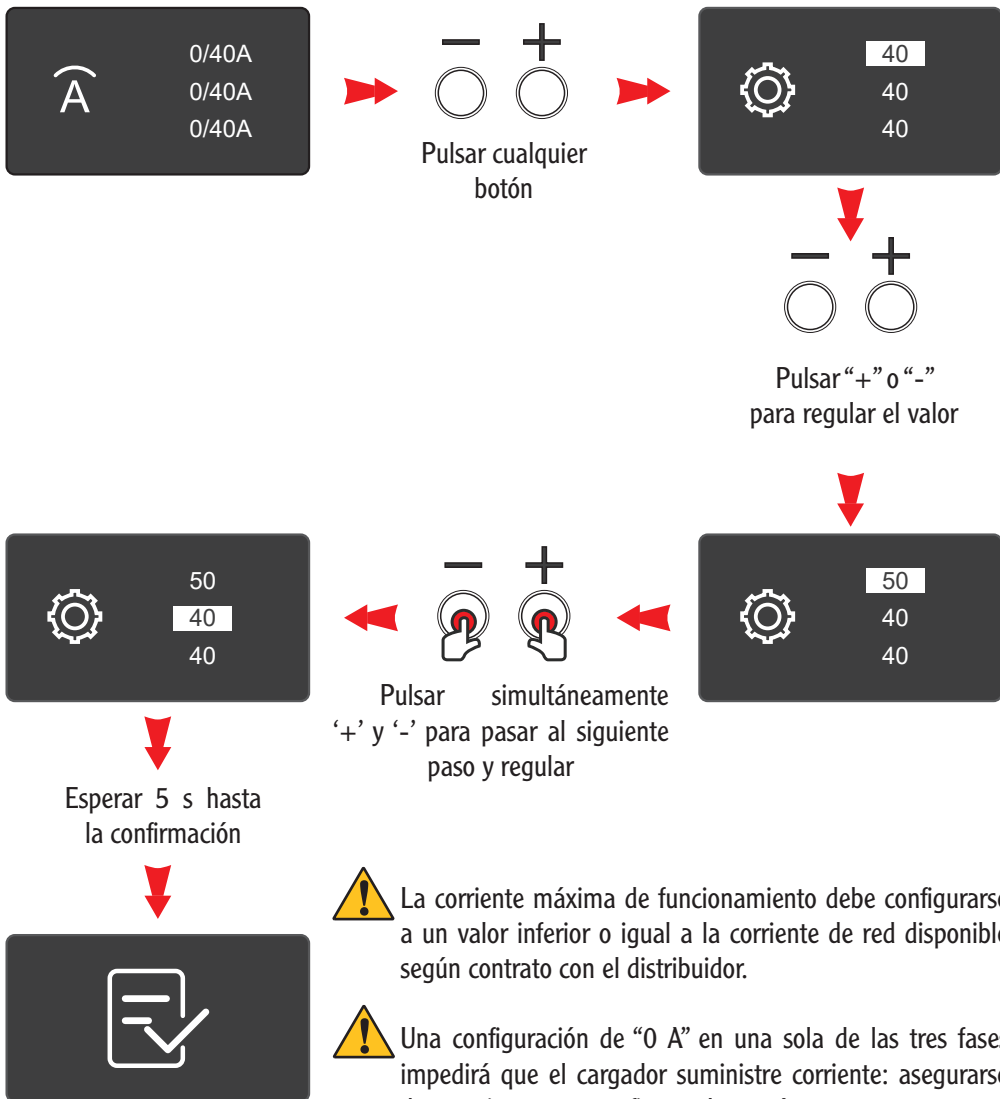

En caso de cambios contractuales con el distribuidor que impliquen un cambio de la potencia máxima y, por tanto, de la corriente, también deberá actualizarse la configuración de corriente máxima del DLB.

- Dispositivo trifásico DLB3



 La corriente máxima de funcionamiento debe configurarse a un valor inferior o igual a la corriente de red disponible según contrato con el distribuidor.





 Una configuración de “0 A” en una sola de las tres fases impedirá que el cargador suministre corriente: asegurarse de que siempre se configuren los parámetros correctos para cada fase.

 En caso de cambios contractuales con el distribuidor que impliquen un cambio de la potencia máxima y, por tanto, de la corriente, también deberá actualizarse la configuración de corriente máxima del DLB.

Solución de problemas para DLB estándar

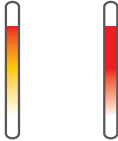

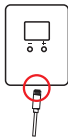
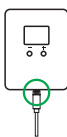
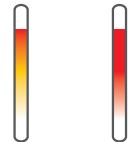
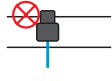
Cualquier trabajo de inspección y/o reparación lo debe realizar personal cualificado.
Las reparaciones y comprobaciones realizadas por uno mismo suponen un alto riesgo eléctrico.

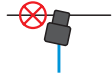
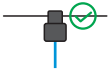
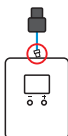
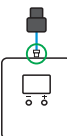
Estado de la luz LED del cargador	Tipo de fallo	Posible causa	Solución
 <p>Secuencia continua de LED amarillo y LED rojo, intermitente</p>	DLB offline	 <p>Cable Ethernet dañado</p>	 <p>Sustituir el cable Ethernet</p>
		 <p>Cable Ethernet mal conectado</p>	 <p>Volver a conectar</p>
 <p>Un parpadeo del LED amarillo seguido de dos parpadeos del LED rojo, en repetición</p>	Fallo en la medición de corriente de DLB	 <p>EITC está conectado al cable de alimentación equivocado</p>	 <p>Comprobar que la posición del TC sea correcta</p>
		 <p>El borne del TC está abierto y no está conectado de forma estable</p>	 <p>Volver a conectar</p>
		 <p>La conexión entre el cable del TC y el DLB es inestable</p>	 <p>Volver a conectar</p>
		<p>El dispositivo DLB no mide la corriente de carga del cargador</p>	<p>Comprobar que la posición del TC sea correcta</p>

3. DLB-PV: ESPECIFICACIONES E INSTALACIÓN

Características de DLB-PV, para sistemas fotovoltaicos



Tipo	DLB1-PV	DLB3-PV
Instalación	monofásico	trifásico
Dimensiones / Peso	82x67x35 mm / 100 g	82x67x35 mm / 100 g
Modo “PV Extreme”	√	√
Posibilidad de funcionamiento sin energía fotovoltaica	√	√
Modo Night Automatic Full Speed	√	√
Transformadores de corriente TC en dotación	2	6
Pantalla	OLED, gráfico	OLED, gráfico
Conexión entre el DLB y el cargador	máx. 300 m (cable de red estándar de 5 m)	
Longitud del cable de cada TC	1,5 m (personalizable hasta 15 m)	
Instalación	Instalación en carril DIN / fijación con tornillos	
Comunicación	RS485 (mediante cable Ethernet)	

i No se necesita ninguna fuente de alimentación adicional: DLB se alimenta del cargador a través de Ethernet

- **Qué es el modo “Extreme”:** con este modo, si la corriente requerida por el cargador doméstico sigue aumentando y la energía proporcionada por el sistema fotovoltaico no es suficiente para mantener la corriente mínima del cargador, la carga se interrumpe para evitar una sobrecarga. La carga se reinicia automáticamente cuando la corriente disponible en la línea es igual o superior a 10 A. Este modo puede activarse a través de la aplicación BIAN.CO Easy (consultar el manual para más información).
- **¿Qué es el modo “Night Automatic Full Speed”?:** con este modo, el cargador sigue cargando el vehículo eléctrico a la máxima velocidad posible desde las 20:00 hasta las 06:00. Este modo puede configurarse y activarse a través de la aplicación BIAN.CO Easy (consultar el manual para más información).

Cómo funciona el dispositivo DLB-PV para sistemas fotovoltaicos

DLB1-PV para el sistema monofásico:

Corriente del cargador = Corriente máxima de red + Corriente fotovoltaica - Corriente de carga doméstica

DLB3-PV para el sistema trifásico:

Corriente del cargador = Corriente máxima de red + (Corriente fotovoltaica - Corriente de carga doméstica) / 3

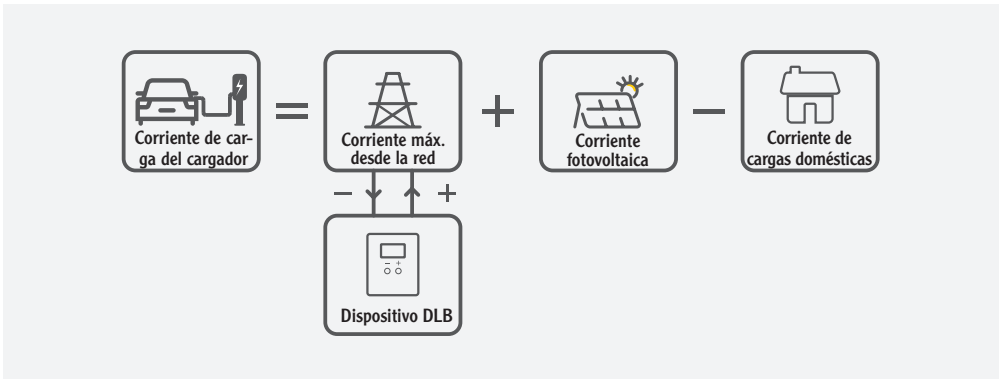

Cómo instalar el dispositivo DLB-PV para sistemas fotovoltaicos

Abra y conecte la(s) pinza(s) CT del(los) transformador(es) de corriente, de acuerdo con uno de los siguientes casos.

CASO 1 - Líneas de carga doméstica y cargadores EV en paralelo

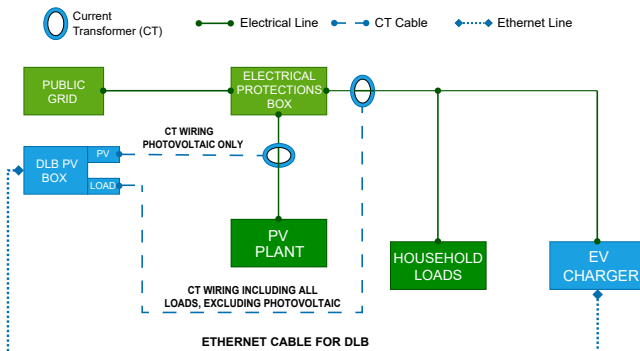

CASO 2 - Líneas de carga doméstica y cargadores EV en serie

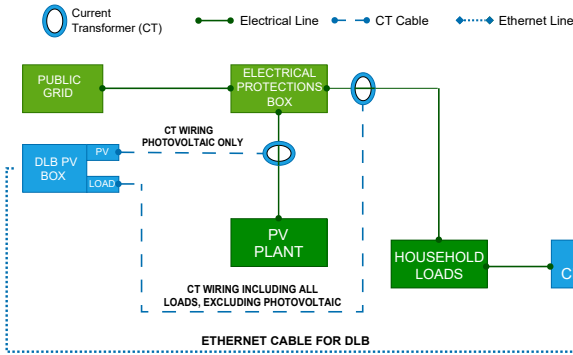

Al igual que en el caso del modelo DLB Standard, la instalación de los TC requiere personal cualificado, ya que pueden estar en contacto con elementos bajo tensión.



Para trabajar con seguridad, se recomienda interrumpir la alimentación del inversor de la instalación fotovoltaica antes de colocar los TC correspondientes.

Qué algoritmos son aplicables a DLB-PV

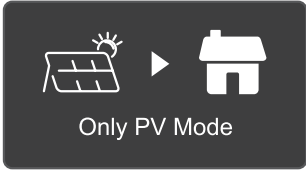
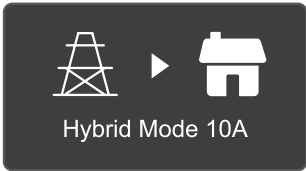
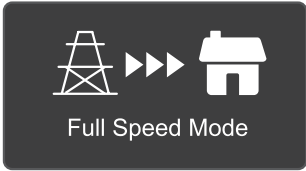
Algoritmo de carga	funcionamiento
Only PV  <p style="text-align: center;">Only PV Mode</p>	El cargador en modo “Only PV” modula automáticamente la corriente de carga máxima para no necesitar corriente adicional de la red pública.
Hybrid  <p style="text-align: center;">Hybrid Mode 10A</p>	El cargador en modo “Hybrid” modula automáticamente la corriente de carga máxima para no consumir nunca más corriente de la configurada.
Full Speed  <p style="text-align: center;">Full Speed Mode</p>	El cargador en modo “Full Speed” modula automáticamente la corriente de carga máxima para maximizar la potencia suministrada, en función de la potencia total disponible.

Cómo cambiar del modo PV al modo Standard (solo para versiones DLB-PV).

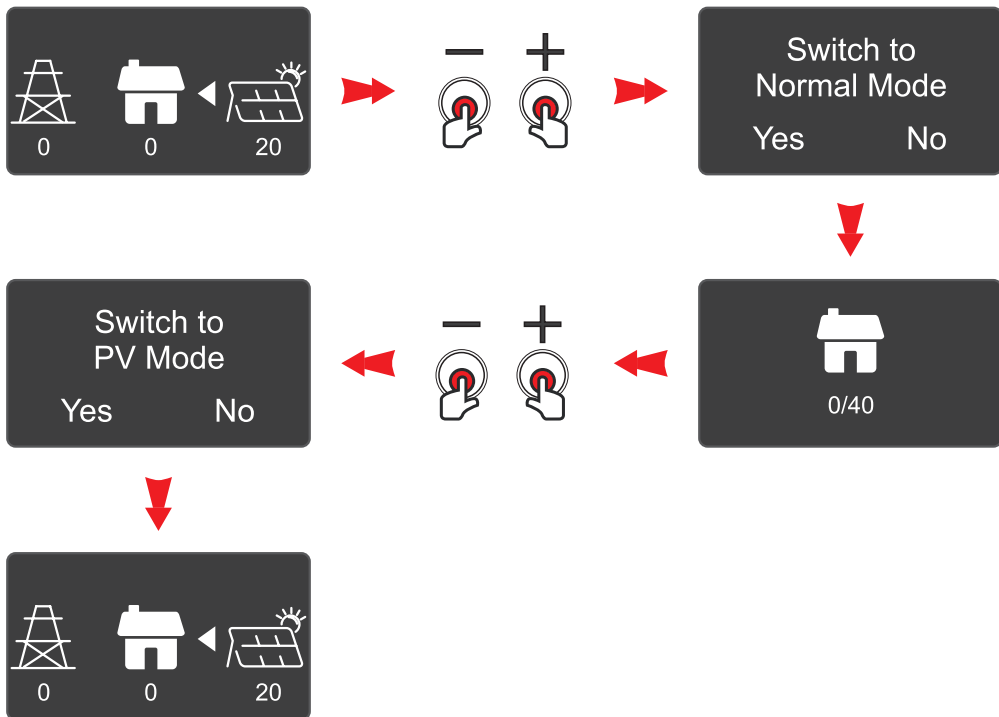



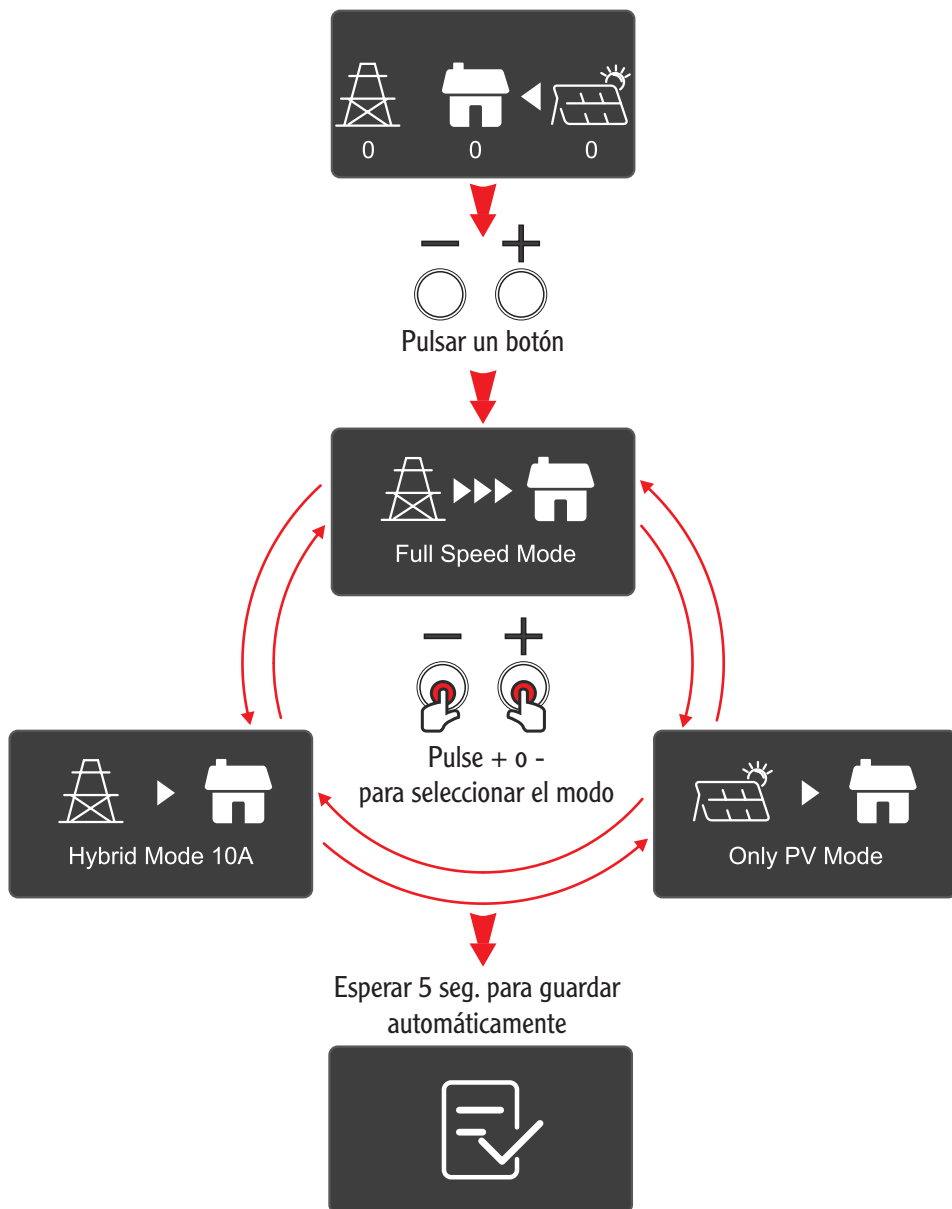



Cómo elegir uno de los algoritmos disponibles (solo para versiones Solar DLB-PV).

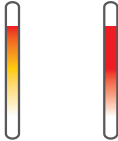

Solución de problemas para DLB-PV

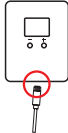
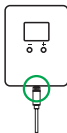
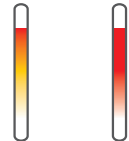
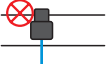

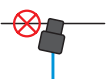
Cualquier trabajo de inspección y/o reparación lo debe realizar personal cualificado.
Las reparaciones y comprobaciones realizadas por uno mismo suponen un alto riesgo eléctrico.

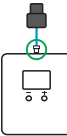
Estado de la luz LED del cargador	Tipo de fallo	Posible causa	Solución
 <p data-bbox="225 344 437 424">Secuencia continua de LED amarillos y rojos, de forma intermitente.</p>	DLB offline	 <p data-bbox="661 376 846 424">El cable Ethernet está dañado</p>	 <p data-bbox="889 376 1034 424">Sustituir el cable Ethernet</p>
		 <p data-bbox="673 592 835 639">Cable Ethernet mal conectado</p>	 <p data-bbox="885 592 1034 616">Volver a conectar</p>
 <p data-bbox="241 807 449 911">Un parpadeo del LED amarillo seguido de dos parpadeos del LED rojo, en repetición.</p>	Fallo en la medición de corriente de DLB	 <p data-bbox="656 775 852 855">El ITC está conectado al cable de alimentación equivocado</p>	 <p data-bbox="885 775 1034 855">Comprobar que la posición del TC sea correcta</p>
		 <p data-bbox="650 975 857 1023">El terminal TC está abierto o mal conectado</p>	 <p data-bbox="885 975 1034 999">Volver a conectar</p>
		 <p data-bbox="650 1198 857 1278">La conexión entre el cable del TC y el DLB es inestable</p>	 <p data-bbox="885 1230 1034 1254">Volver a conectar</p>
		<p data-bbox="661 1310 846 1390">El dispositivo DLB no mide la corriente de carga del cargador</p>	<p data-bbox="885 1310 1034 1390">Comprobar que la posición del TC sea correcta</p>

– La siguiente información se refiere a los Estados miembros de la Unión Europea:



INFORMACIÓN A LOS USUARIOS Aplicación de la Directiva 2012/19/UE.

El símbolo del contenedor de basura tachado en el aparato o en su embalaje indica que el producto, al final de su vida útil, debe recogerse por separado de otros residuos.

La recogida selectiva de estos aparatos al final de su vida útil la organiza y gestiona el fabricante. Por lo tanto, los usuarios que deseen deshacerse de estos equipos deberán ponerse en contacto con el fabricante y seguir el sistema que éste haya adoptado para permitir la recogida selectiva de los equipos al final de su vida útil.

Una recogida selectiva adecuada para el posterior reciclado, tratamiento y eliminación respetuosa con el medio ambiente de los equipos desechados contribuye a evitar posibles efectos negativos sobre el medio ambiente y la salud y favorece la reutilización y/o reciclado de los materiales con los que están fabricados los equipos.

La eliminación no autorizada del producto por parte del titular dará lugar a la aplicación de las sanciones administrativas previstas.

Condiciones de garantía

- El fabricante garantiza que el producto está libre de defectos de material, diseño y fabricación y que es apto para su uso, tras una correcta instalación, durante 2 años a partir de la fecha de compra.
- La garantía no cubre los daños causados por fallos de funcionamiento no imputables al propio producto, fenómenos naturales, instalación o mantenimiento incorrectos o realizados por personas no cualificadas, uso contrario a las instrucciones o desgaste normal por el uso. En cualquier caso, la garantía no cubre los perjuicios económicos derivados de la imposibilidad de utilizar el producto o de la falta de carga del vehículo, ni los daños causados al vehículo por el uso de un producto que no funcione correctamente.
- Las condiciones de garantía de los productos CEMBRE se encuentran en la página web **www.cembre.com**, dentro de las condiciones generales de venta.
- El producto solo lo deben instalar y reparar profesionales cualificados que certifiquen que se ha realizado de forma profesional.
- En caso de defectos, fallos o mal funcionamiento durante la instalación o el uso del producto y, en cualquier caso, para hacer uso de la garantía, ponerse en contacto con el distribuidor.

Nota: CEMBRE se reserva el derecho a actualizar el contenido de este documento sin previo aviso y en cualquier momento. Se ruega comprobar si hay actualizaciones mediante el código QR del envase.

1. INFORMAÇÕES GERAIS

Módulo DLB Standard

Os carregadores da série BIAN.CO podem ser equipados com um dispositivo DLB (Dynamic Load Balancing) para um equilíbrio dinâmico da carga. É constituído por um módulo que pode ser instalado numa calha DIN ou num suporte plano e por um ou mais transformadores amperométricos (ou “CT”) de abrir, a ligar aos condutores de fase: quando estão presentes outras cargas na linha do carregador, o DLB é capaz de limitar automaticamente a absorção total de corrente do carregador, de modo a não tornar o sistema de carregamento a principal causa de uma sobrecarga na linha de alimentação.

DLB1 (monofásico)

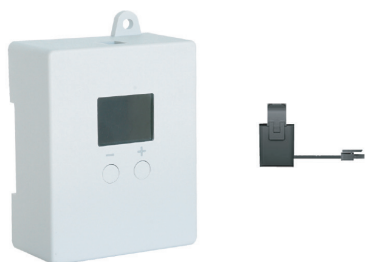

DLB3 (trifásico)

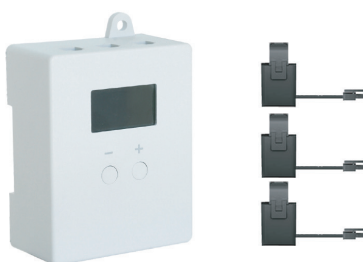

Módulo DLB-PV (para sistema fotovoltaico)

O DLB-PV também permite a integração de um sistema fotovoltaico no sistema: para além da funcionalidade do DLB Standard, o DLB-PV é capaz de explorar o contributo do sistema fotovoltaico, otimizando e/ou maximizando o fornecimento de diferentes formas:

- **Full Speed Mode** utiliza tanto a energia fornecida pela linha de alimentação como pelo sistema fotovoltaico
- **Only PV Mode** utiliza apenas a energia produzida pelo sistema fotovoltaico
- **Modo híbrido** (maximiza o fornecimento utilizando o sistema fotovoltaico e uma quantidade máxima de alimentação da rede configurável)



DLB1-PV (monofásico)

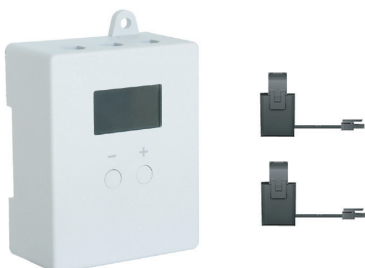

DLB3-PV (trifásico)

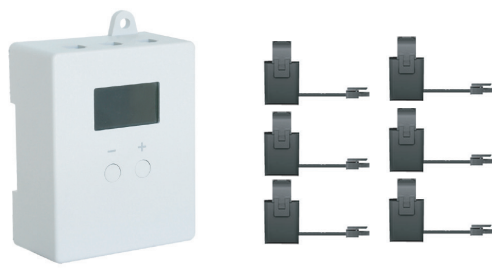

O DLB-PV também pode ser utilizado como DLB Standard sem integração do sistema fotovoltaico.

Na embalagem:

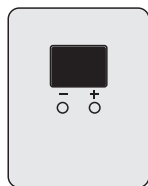

Dispositivo DLB
X1



Calha Din 105 mm

X1



Peças para fixação da calha Din

X2



Parafuso de expansão
M4x30

X2



Transformador de corrente (CT)

X1 (DLB monofásico)

X3 (DLB3 trifásico)

X2 (DLB-PV monofásico)

X6 (DLB3-PV trifásico)





Cabo de rede - 5 m

(cabo RJ45 TIA/EIA-568B cat5 de 8 condutores)

X1

2. DLB STANDARD: ESPECIFICAÇÕES E INSTALAÇÃO

Especificações do DLB Standard

		
Tipo	DLB1	DLB3
Instalação	monofásico	trifásico
Dimensões/Peso	82x67x35 mm/100 g	82x67x35 mm/100 g
Modo “Extreme”	√	√
standard para fotovoltaico/fotovoltaico para standard	-	-
Modo Night Automatic Full Speed	-	-
Transformadores de corrente fornecidos	1	3
Ecrã	LED, de segmentos	OLED, gráfico
Ligação entre o DLB e o carregador	num raio de 300 m (cabo de rede standard de 5 m)	
Comprimento standard cabo CT	1,5 m (personalizável até 15 m)	
Instalação	Instalação em calha DIN/fixação por parafuso	
Comunicação	RS485 (via cabo ethernet)	

i Não é necessária qualquer alimentador adicional: o DLB é alimentada pelo carregador através da Ethernet.

- **O que é o modo “Extreme”:** Neste modo, se a corrente exigida pelas cargas domésticas continuar a aumentar, o carregamento é suspenso para evitar a sobrecarga.
O carregamento é retomado quando voltar a estar disponível uma corrente de, pelo menos, 10 A.
O modo DLB Extreme pode ser ativado através da aplicação BIAN.CO Easy (para os modos de ativação, consulte o manual dedicado).

Como funciona o dispositivo DLB

Para o sistema DLB monofásico (DLB1):

Corrente do carregador = corrente máxima de rede (definida em DLB) - Corrente de carga doméstica

Para o sistema DLB trifásico (DLB3):

Corrente do carregador = a menor entre:

corrente máxima da rede de fase L1 (definida em DLB) - Corrente de carga doméstica fase L1

corrente máxima da rede de fase L2 (definida em DLB) - Corrente de carga doméstica fase L2

corrente máxima da rede de fase L3 (definida em DLB) - Corrente de carga doméstica fase L3

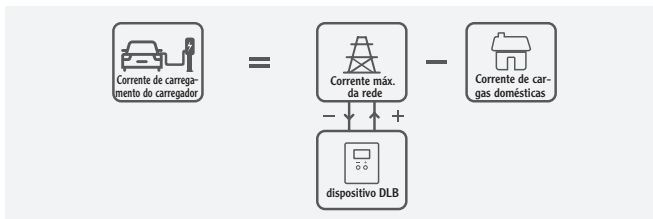

Estações de carregamento múltiplas

Assumindo a condição de que, no momento em que o carregador 2 inicia uma sessão de carregamento, o carregador 1 já está a carregar um veículo:

- Corrente máxima do carregador 1 = Corrente máxima de rede (definida em DLB) - Corrente de carga doméstica
- Corrente máxima do carregador 2 = Corrente máxima de rede (definida em DLB) - Corrente de carga doméstica - Carregador 1.

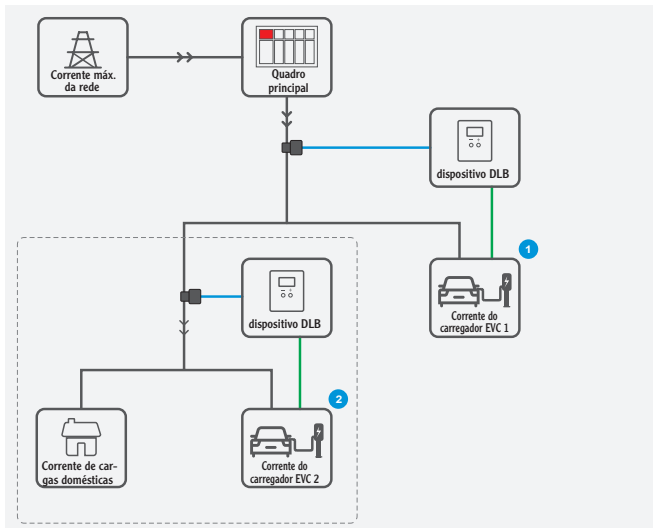

Como instalar o dispositivo DLB



A instalação dos CT requer o contacto com condutores potencialmente sob tensão: os trabalhos de instalação devem, portanto, ser executados por pessoal qualificado e profissional.



O posicionamento incorreto dos CT provoca o mau funcionamento do DLB: siga escrupulosamente as instruções fornecidas neste manual.



Na versão trifásica DLB3, a sequência de fases deve ser respeitada e deve ser a mesma que a utilizada para o carregador. As inversões de fase podem provocar falhas no sistema DLB.

STEP 1 - Instalação do transformador de corrente (CT)

- Abra e ligue o(s) grampo(s) CT do(s) transformador(es) de corrente, conforme um dos seguintes casos.

CASO 1 - Linhas de carga doméstica e carregador EV em paralelo

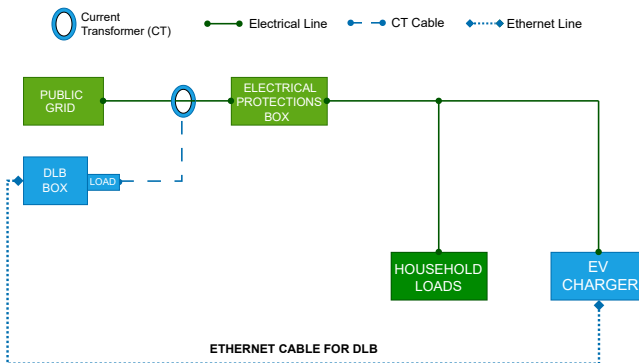

CASO 2 - Linhas de carga doméstica e carregador EV em série

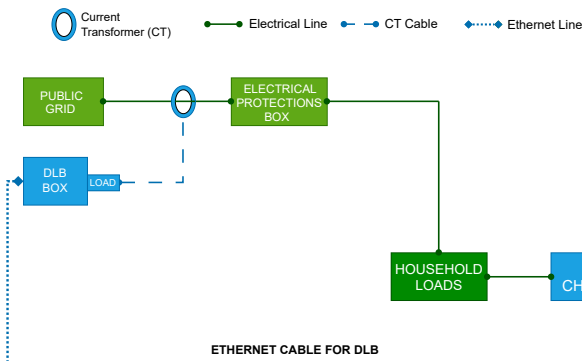

caso 3 - Instalação fotovoltaica com DLB standard (não DLB-PV fotovoltaico)

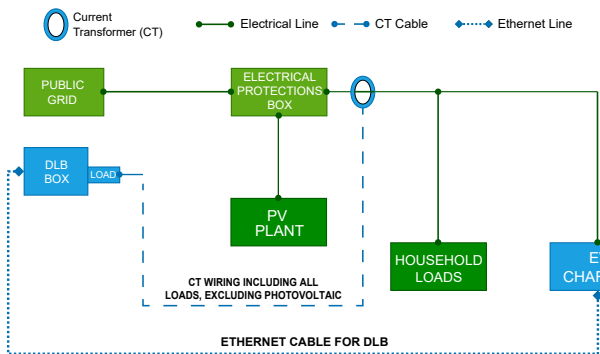

! Estes esquemas de cablagem são aplicáveis apenas a DLB1 e DLB3; consulte as páginas seguintes para DLB1-PV e DLB3-PV.

- No caso de DLB monofásico, ligue o CT ao condutor de fase da rede (ver figura).
- No caso de DLB3 trifásico, ligue os três CT, um em cada fase (ver figura).
- Ligue corretamente os cabos dos CT ao dispositivo DLB: a presença de conectores na cabeça do cabo de cada CT facilita e estabiliza a ligação ao DLB.

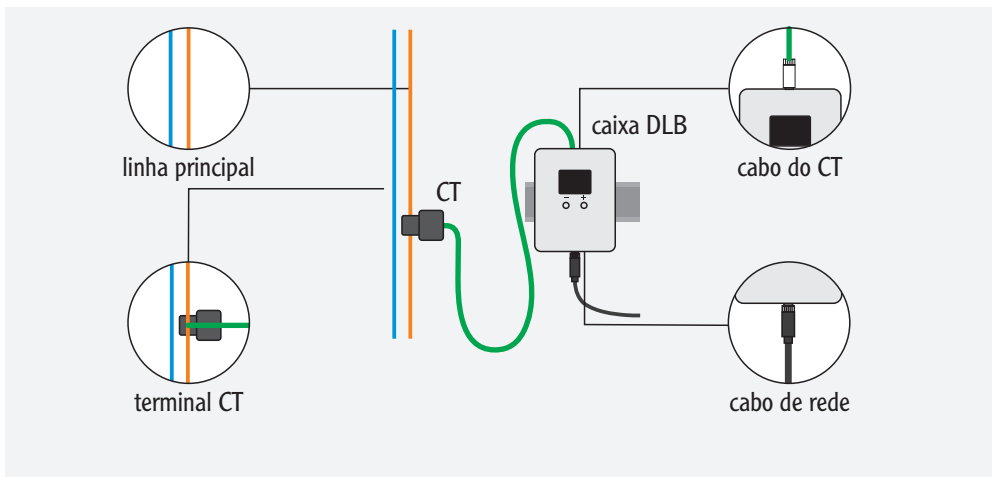
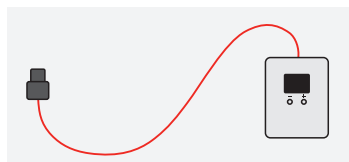
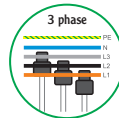
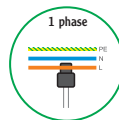

PASSO 2 - Ligação ao carregador através do cabo de rede

Ligue o dispositivo DLB ao carregador através do cabo de rede: este cabo transporta a alimentação e os dados de comunicação entre o carregador e o dispositivo DLB.

Procedimento:

1. Interrompa a linha de alimentação do carregador.
2. Remova o painel frontal do carregador.
3. Insira o cabo Ethernet no interior do carregador; os modos possíveis de entrada do cabo são indicados no manual de instalação do carregador.
4. Identifique a porta Ethernet na placa eletrônica (ver figura) e ligue o cabo Ethernet à mesma.
5. Volte a colocar o painel frontal do carregador e reative a linha de alimentação.
6. Ligue a outra extremidade do cabo Ethernet na parte inferior da DLB, se a caixa DLB arrancar, pode prosseguir com os passos seguintes.
7. Volte a ligar o carregador: basta desligar a alimentação durante 5 segundos e voltar a ligar.

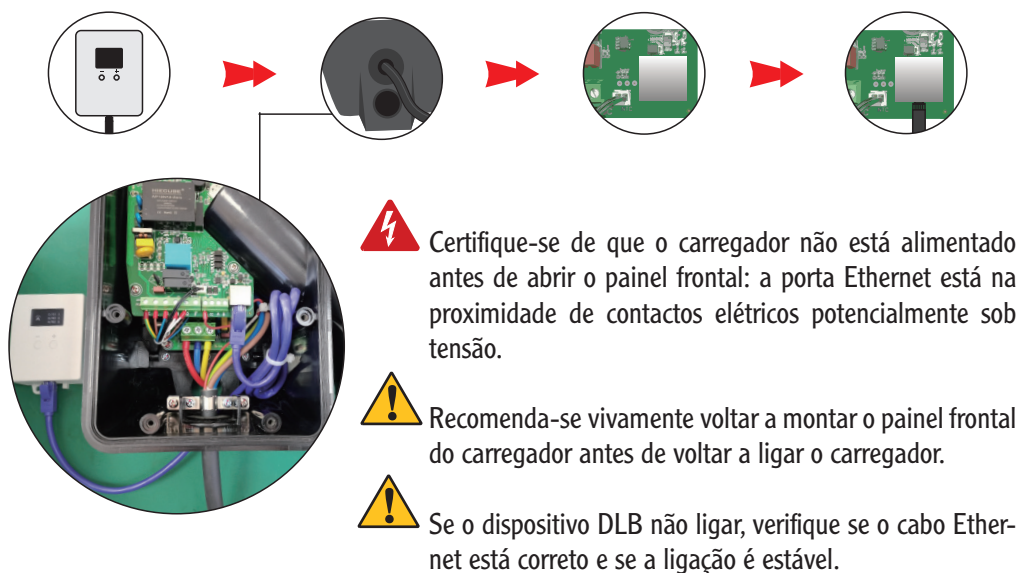

Cabo de rede recomendado



Como definir a corrente de rede máxima no dispositivo DLB Standard

- Dispositivo monofásico DLB1



Corrente medida



Prima qualquer
botão



Valor definido



Prima “+” ou “-” para
regular o valor



Valor definido



Aguarde 5 seg.
para guardar
automaticamente

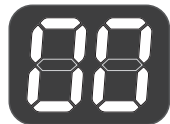

Corrente medida





Para poder operar corretamente, a corrente máxima de funcionamento deve ser definida num valor inferior ou igual à corrente de rede disponível por contrato com a entidade distribuidora.



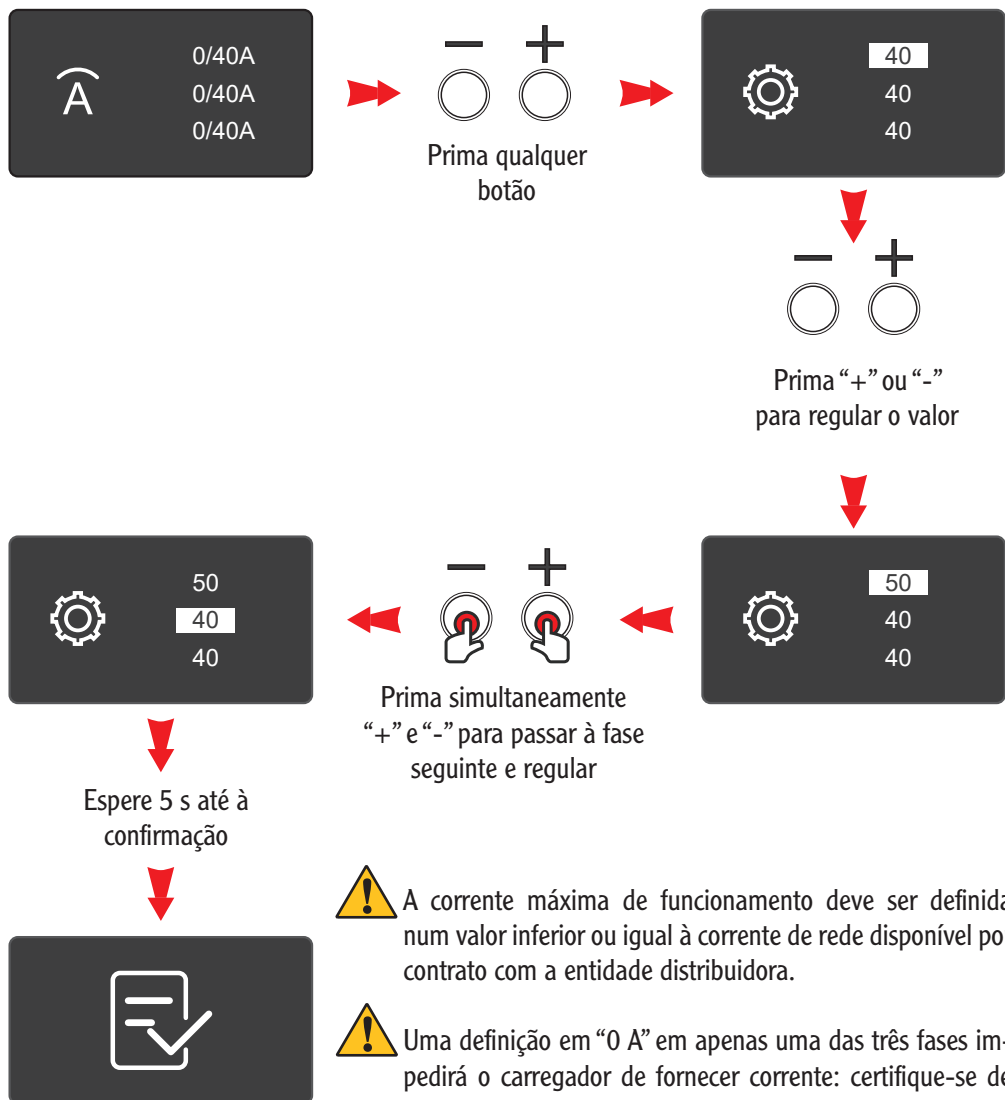

No caso de alterações contratuais com a entidade distribuidora que impliquem uma alteração da potência máxima e, consequentemente, da corrente, a definição da corrente máxima do DLB também deve ser atualizada.

- Dispositivo trifásico DLB3



 A corrente máxima de funcionamento deve ser definida num valor inferior ou igual à corrente de rede disponível por contrato com a entidade distribuidora.







 Uma definição em “0 A” em apenas uma das três fases impedirá o carregador de fornecer corrente: certifique-se de que são sempre definidos os parâmetros corretos para cada fase.

 No caso de alterações contratuais com a entidade distribuidora que impliquem uma alteração da potência máxima e, conseqüentemente, da corrente, a definição da corrente máxima do DLB também deve ser atualizada.

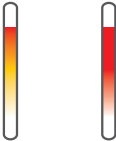
Resolução de problemas no DLB Standard

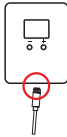
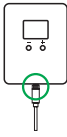
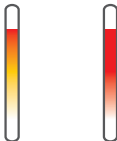

Quaisquer operações de controlo e/ou reparação devem ser efetuadas por pessoal qualificado. As reparações e verificações efetuadas pelo próprio constituem um risco elétrico elevado.

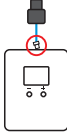
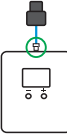
Estado da luz LED no carregador	Tipo de avaria	Causa possível	Solução
 <p>Sequência contínua do LED amarelo e LED vermelho, intermitente</p>	DLB offline	 <p>Cabo Ethernet danificado</p>	 <p>Substitua o cabo ethernet</p>
		 <p>Cabo Ethernet ligado incorretamente</p>	 <p>Volte a ligá-lo</p>
 <p>Uma intermitência do LED amarelo seguida de duas intermitências do LED vermelho, repetidamente</p>	Falha na medição da corrente do DLB	 <p>O CT está ligado ao cabo de alimentação errado</p>	 <p>Verifique se a posição do CT está correta</p>
		 <p>O terminal do CT está aberto e não está ligado de forma estável</p>	 <p>Volte a ligá-lo</p>
		 <p>A ligação entre o cabo do CT e o DLB é instável</p>	 <p>Volte a ligá-lo</p>
		<p>O dispositivo DLB não mede a corrente de carga do carregador</p>	<p>Verifique se a posição do CT está correta</p>

3. DLB-PV: ESPECIFICAÇÕES E INSTALAÇÃO

Características dos DLB-PV, para sistemas fotovoltaicos



Tipo	DLB1-PV	DLB3-PV
Instalação	monofásico	trifásico
Dimensões/Peso	82x67x35 mm/100 g	82x67x35 mm/100 g
Modo “PV Extreme”	√	√
Possibilidade de funcionamento sem sistema fotovoltaico	√	√
Modo Night Automatic Full Speed	√	√
Transformadores de corrente CT fornecidos	2	6
Ecrã	OLED, gráfico	OLED, gráfico
Ligação entre o DLB e o carregador	num raio de 300 m (cabo de rede standard de 5 m)	
Comprimento do cabo do CT simples	1,5 m (personalizável até 15 m)	
Instalação	Instalação em calha DIN/fixação por parafuso	
Comunicação	RS485 (via cabo ethernet)	

i Não é necessária qualquer alimentador adicional: o DLB é alimentado pelo carregador através da Ethernet

- **O que é o modo “Extreme”:** neste modo, se a corrente exigida pelas cargas domésticas continuar a aumentar e a energia fornecida pelo sistema fotovoltaico não for suficiente para manter a corrente mínima do carregador, o carregamento é interrompido para evitar uma sobrecarga. O carregamento é automaticamente reiniciado quando a disponibilidade de corrente na linha é igual ou superior a 10A.

Este modo pode ser ativado através da aplicação BIAN.CO Easy (para mais informações, consulte o manual).

- **O que é o modo “Night Automatic Full Speed”:** neste modo, o carregador continua a carregar o veículo elétrico à velocidade mais elevada possível, das 20:00 às 06:00.

Este modo pode ser configurado e ativado através da aplicação BIAN.CO Easy (para mais informações, consulte o manual).

Como funciona o dispositivo DLB-PV para sistemas fotovoltaicos

DLB1-PV para o sistema monofásico:

Corrente do carregador = Corrente máxima de rede + Corrente Fotovoltaico - Corrente de cargas domésticas

DLB3-PV para o sistema trifásico:

Corrente do carregador = Corrente máxima de rede + (Corrente Fotovoltaico - Corrente de cargas domésticas) / 3

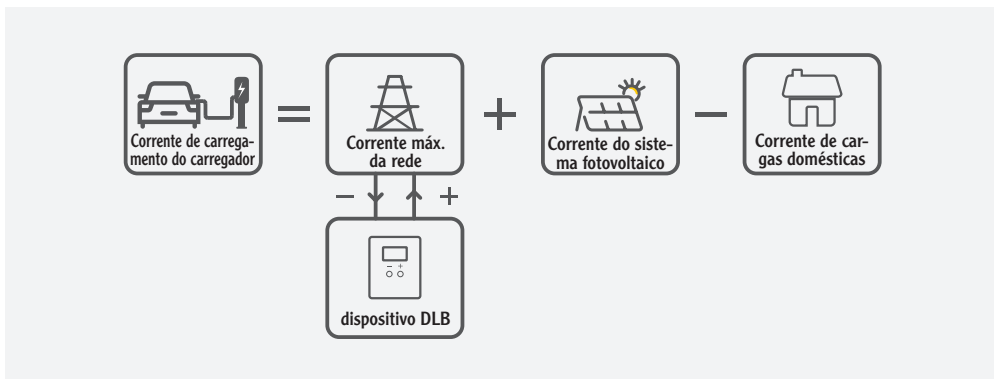

Como instalar o dispositivo DLB-PV para sistemas fotovoltaicos

Abra e ligue o(s) grampo(s) CT do(s) transformador(es) de corrente, conforme um dos seguintes casos.

caso 1 - Linhas de carga doméstica e carregador EV em paralelo

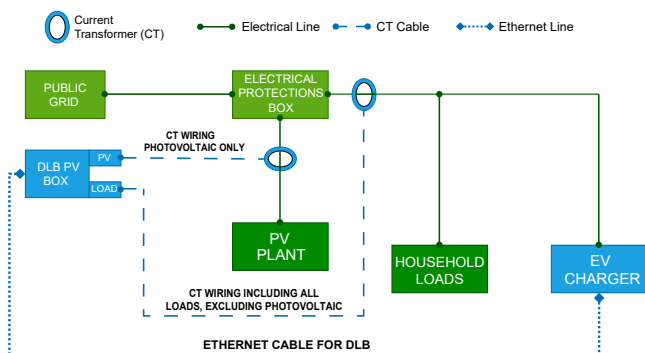

caso 2 - Linhas de carga doméstica e carregadores EV em série

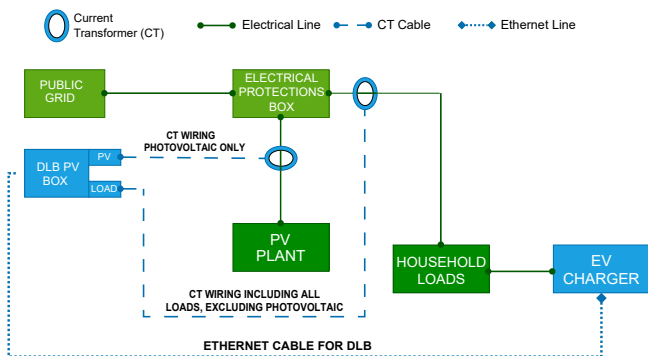

 Tal como acontece com o DLB Standard, a instalação dos CT requer pessoal qualificado, uma vez que estão potencialmente em contacto com partes sob tensão.

 Para trabalhar em condições de segurança, recomenda-se a interrupção da alimentação do inversor do sistema fotovoltaico antes de posicionar o CT.

Que algoritmos são aplicáveis ao DLB-PV

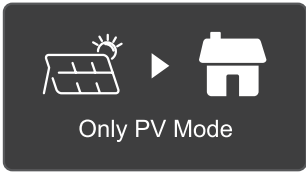
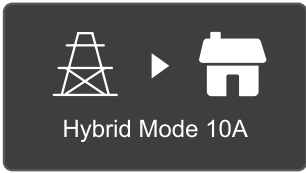
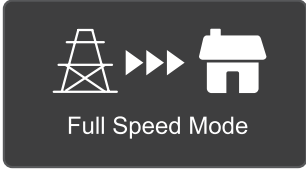
Algoritmo de carregamento	funcionamento
Only PV  <p style="text-align: center;">Only PV Mode</p>	O carregador no modo “Only PV” modula automaticamente a corrente máxima de carregamento, para não necessitar de corrente adicional da rede pública
Hybrid  <p style="text-align: center;">Hybrid Mode 10A</p>	O carregador no modo “Hybrid” modula automaticamente a corrente máxima de carregamento, para nunca absorver mais corrente da rede do que a definida
Full Speed  <p style="text-align: center;">Full Speed Mode</p>	O carregador no modo “Full Speed” modula automaticamente a corrente máxima de carregamento, para maximizar a potência fornecida, em função da potência total disponível

Como passar do modo PV para o modo Standard (apenas para versões DLB-PV)

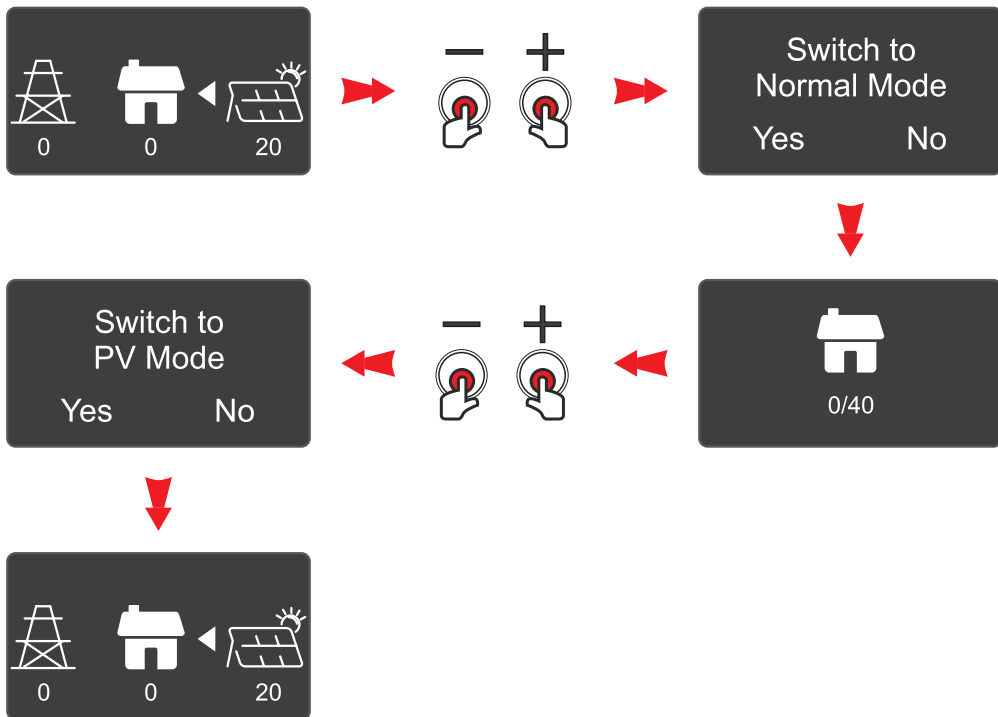

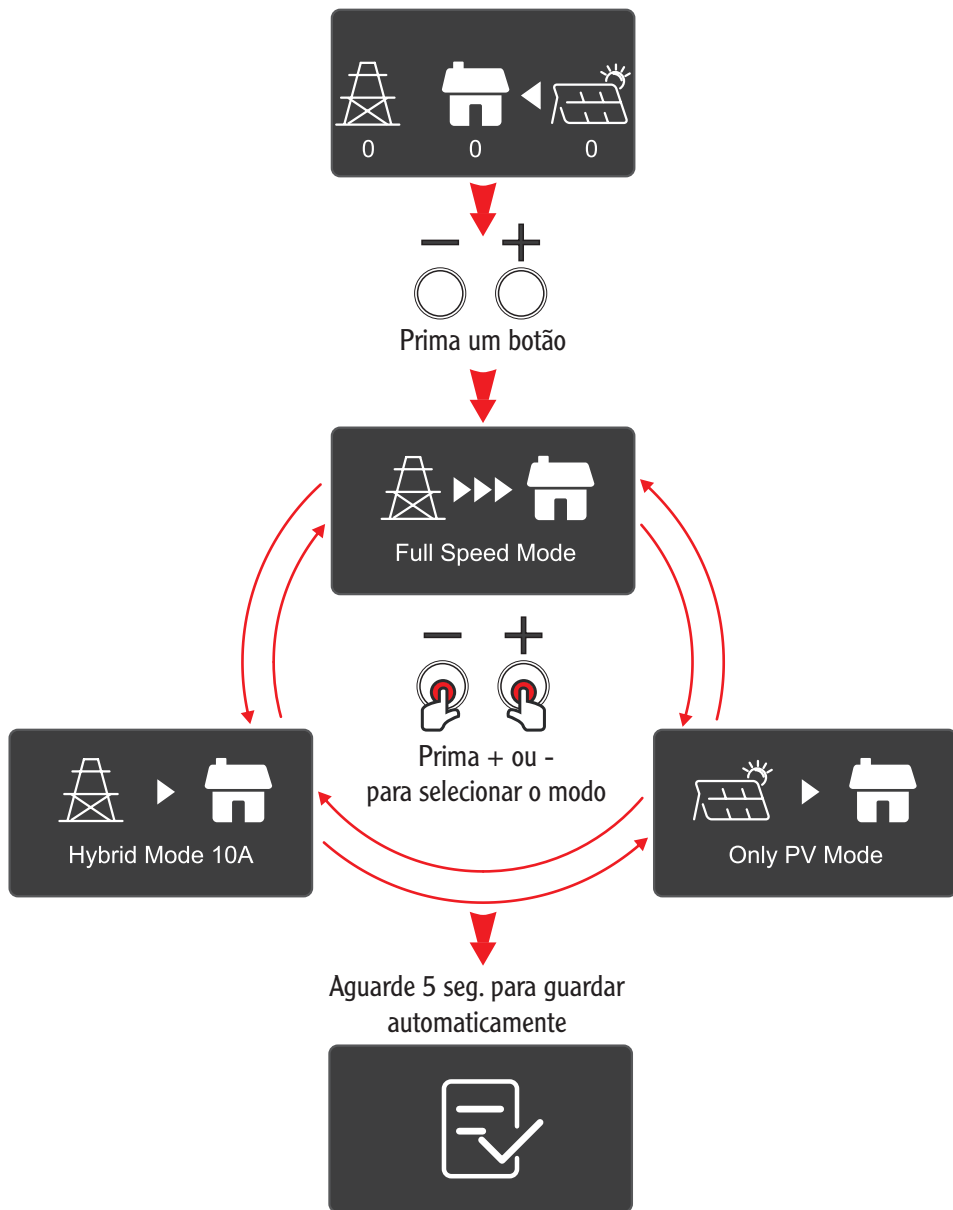

Como escolher um dos algoritmos disponíveis (apenas para versões DLB-PV)



Resolução de problemas no DLB-PV

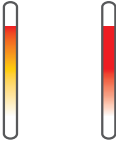

Quaisquer operações de controlo e/ou reparação devem ser efetuadas por pessoal qualificado. As reparações e verificações efetuadas pelo próprio constituem um risco elétrico elevado.

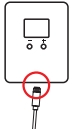
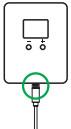
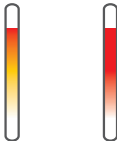
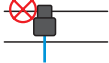
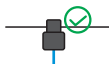
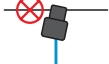
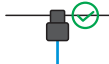
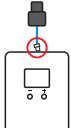
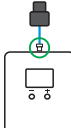
Estado da luz LED no carregador	Tipo de avaria	Causa possível	Solução
 <p data-bbox="225 368 421 448">Sequência contínua do LED amarelo e LED vermelho, intermitente.</p>	DLB offline	 <p data-bbox="664 400 844 448">O cabo Ethernet está danificado</p>	 <p data-bbox="889 400 1034 448">Substitua o cabo ethernet</p>
		 <p data-bbox="664 616 844 663">Cabo Ethernet ligado incorretamente</p>	 <p data-bbox="900 616 1023 639">Volte a ligá-lo</p>
 <p data-bbox="244 826 437 970">Uma intermitência do LED amarelo seguida de duas intermitências do LED vermelho, repetidamente.</p>	Falha na medição da corrente do DLB	 <p data-bbox="664 791 844 871">O CT está ligado ao cabo de alimentação errado</p>	 <p data-bbox="900 791 1023 871">Verifique se a posição do CT está correta</p>
		 <p data-bbox="650 970 855 1050">O terminal do CT está aberto e não está ligado de forma correta</p>	 <p data-bbox="900 1002 1023 1026">Volte a ligá-lo</p>
		 <p data-bbox="647 1217 859 1265">A ligação entre o cabo do CT e o DLB é instável</p>	 <p data-bbox="900 1217 1023 1241">Volte a ligá-lo</p>
		<p data-bbox="658 1297 847 1377">O dispositivo DLB não mede a corrente de carga do carregador</p>	<p data-bbox="900 1297 1023 1377">Verifique se a posição do CT está correta</p>

– As informações seguintes dizem respeito aos Estados-Membros da União Europeia:



INFORMAÇÃO AOS UTILIZADORES Aplicação da Diretiva 2012/19/UE.

O símbolo do contentor do lixo barrado com uma cruz no equipamento ou na sua embalagem indica que o produto, no fim da sua vida útil, deve ser recolhido separadamente dos outros resíduos. A recolha separada deste equipamento em fim de vida é organizada e gerida pelo fabricante. O utilizador que pretenda desfazer-se deste equipamento deve, portanto, contactar o fabricante e seguir o sistema que este adotou para permitir a recolha separada do equipamento em fim de vida. Uma recolha separada adequada para posterior encaminhamento do equipamento fora de uso para reciclagem, tratamento e eliminação ambientalmente correta ajuda a evitar possíveis efeitos negativos no ambiente e na saúde e promove a reutilização e/ou reciclagem dos materiais que compõem o equipamento.

A eliminação não autorizada do produto pelo detentor implicará a aplicação das sanções administrativas previstas.

Condições da garantia

- O fabricante garante que o produto está isento de defeitos de material, conceção e fabrico e que é adequado para utilização, após uma instalação efetuada de forma profissional, durante 2 anos a partir da data de compra.
- A garantia não cobre quaisquer danos causados por avarias não imputáveis ao próprio produto, fenómenos naturais, instalação ou manutenção incorretas ou manutenção efetuadas por pessoas não qualificadas, utilização contrária às instruções, desgaste normal de utilização. Em qualquer caso, a garantia não cobre os danos financeiros resultantes da impossibilidade de utilizar o produto ou do não carregamento do veículo, nem os danos causados ao veículo pela utilização de um produto que não esteja totalmente funcional.
- Os termos e condições de garantia dos produtos CEMBRE podem ser consultados no sítio Web **www.cembre.com**, nas condições gerais de venda.
- A instalação e a reparação do produto só devem ser efetuadas por profissionais qualificados, que atestem que foram realizadas de forma profissional.
- Em caso de defeitos, avarias ou mau funcionamento que ocorram durante a instalação ou utilização do produto, e em qualquer caso para o exercício da garantia, contacte o seu revendedor.

Nota: A CEMBRE reserva-se o direito de atualizar o conteúdo deste documento sem aviso prévio e em qualquer momento. Verifique se há atualizações utilizando o código QR presente na embalagem.

NOTES

NOTES

NOTES



CEMBRE S.p.A.
via Serenissima, 9
25135 Brescia
Italy
Ph +39 030 36921
ufficio.vendite@cembre.com
sales@cembre.com

CEMBRE Ltd.
Dunton Park,
Kingsbury Road,
Curdworth, Sutton Coldfield
West Midlands, B76 9EB
United Kingdom
Ph +44 01675 470440
sales@cembre.co.uk

CEMBRE S.a.r.l.
129 rue Servient
69003 Lyon
France
Tél. +33 1 60 49 11 90
info@cembre.fr

CEMBRE España S.L.U.
Calle Verano 6 y 8
Pl Las Monjas
28850 Torrejón de Ardoz
Madrid - Spain
Ph +34 91 4852580
comercial@cembre.com

CEMBRE GmbH
Geschäftsbereich
Energie- und Bahntechnik
Heidenmannstr. 166
80939 München
Germany
Ph + 49 89-3580676
info@cembre.de



CEMBRE GmbH
Geschäftsbereich
Industrie und Handel
Boschstraße 7
71384 Weinstadt
Germany
Ph +49 7151-20536-60
info-w@cembre.de



CEMBRE Inc.
Raritan Center Business Park
300 Columbus Circle-S.F,
Edison, NJ 08837 USA
Ph +1 (732) 225-7415
sales.us@cembre.com
Midwest Office
1051 Perimeter Dr. #470
Schaumburg, IL 60173

www.cembre.com

This manual is the property of CEMBRE: any reproduction is forbidden without written permission.
Questo manuale è proprietà di CEMBRE: ogni riproduzione è vietata se non autorizzata per iscritto.
Ce manuel est la propriété de CEMBRE : toute reproduction est interdite sauf autorisation écrite.
Este manual es propiedad de CEMBRE: toda reproducción está prohibida salvo autorización por escrito.
Este manual é propriedade da CEMBRE: qualquer reprodução é proibida exceto se autorizada por escrito.